

User Guide

Viega Stainless Manifold Shut-Off - Balancing

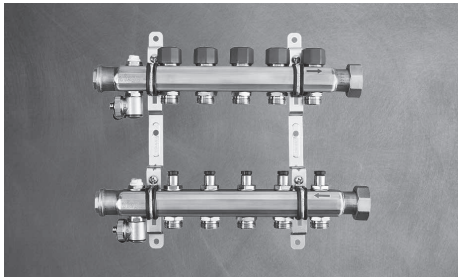

Mounting Instructions

Stainless Manifolds are typically mounted to a wall or within a manifold cabinet.

Mounting the Stainless Manifold to a Wall

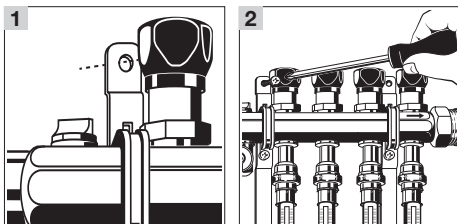

- 1 Insert screws through the manifold bracket mounting holes and into the wall.
- 2 The manifold should be secured at four points located at the top and bottom of each mounting bracket. If mounting to sheetrock; verify the screws are long enough to tighten into framing members within the wall.

Mounting the Stainless Manifold within a Manifold Cabinet

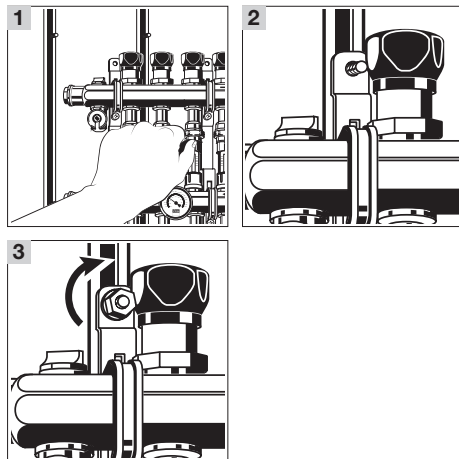

- 1 Position the manifold bracket over the mounting hardware within the cabinet.
- 2 Adjust the rails and hardware until the manifold is located properly. The manifold should be secured at four points located at the top and bottom of each mounting bracket.
- 3 Install the four nuts over the mounting bracket and tighten all mounting hardware.



This document is subject to updates. For the most current Viega technical literature please visit www.viega.us.



Viega products are designed to be installed by licensed and trained plumbing and mechanical professionals who are familiar with Viega products and their installation. **Installation by non-professionals may void Viega LLC's warranty.**

Operation

End Connections

- Use only Viega's manifold adapters to connect manifold.
- Make sure that the black flat washer is placed in the union connection for proper seal.
- DO NOT use teflon tape or thread sealant paste on union connection.
- When extending the manifold, Viega requires using thread sealant paste on the 1" NPT manifold end connection.

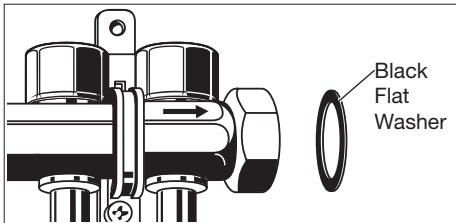

SVC
Compression
PEX Adapters
attach PEX
tubing to
manifolds.



SVC
Compression
Copper Adapters
connect 1/2" and 3/4" copper
tubing to SVC
seat without
soldering.



SVC Press
Adapters
allow the
Viega press
connection
system to
be used on
manifolds.

Circuit connection configuration

Some applications will require the tubing to be brought to the manifold from above. In this type of situation, the purge valve and air bleeder will need to be switched along with flipping the manifold over.

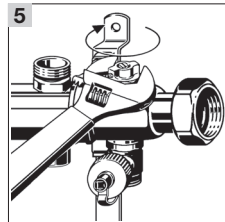
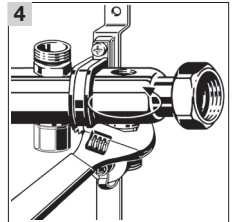
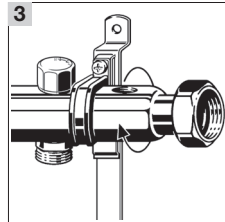
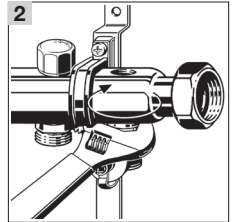
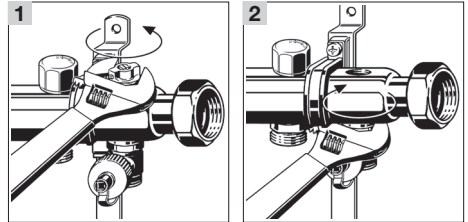

- 1 Remove air bleeder.
- 2 Remove purge valve.
- 3 Flip manifold over.
- 4 Attach purge valve.
- 5 Attach air bleeder.

Pressure Testing

Before the finish floor is installed and during concrete pouring the radiant system must be pressure tested. Air or water may be used as the medium.

The following procedure is recommended by Viega. Check the local building codes for compliance or additional test requirements.



If the tubing is damaged, repair punctured section with a coupling.

Procedure:

- 1 Double check all connections to manifold to ensure proper seal.
- 2 Connect manifold pressurization kit (1) to any purge valve (2).
- 3 Pressurize the system to 100 psi to detect potential nail or screw penetrations.
- 4 The system should hold the 100 psi for a minimum of 1 hour.

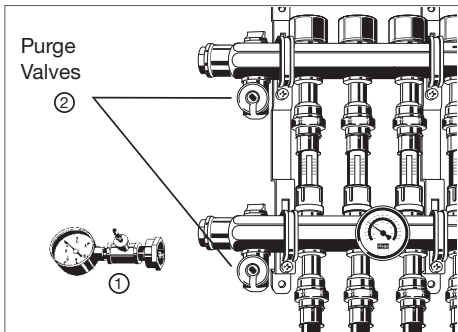

Purging

- 1 Attach drain hose to purge valve hose connection on return manifold and open valve with valve cap.
- 2 Close all but one balancing valve on supply manifold using a 5 mm allen wrench or included valve key (reference Initial Balancing steps). Close isolation ball valve on boiler return line if mixing station is attached. Remove plastic dust cap or temperature controller from 3-way valve, and make sure that high limit kit is fully open (refer to mixing station product instructions).
- 3 Open boiler fast fill valve to purge circuit. After purging first circuit, close valve and open next one. Continue with one circuit at a time until all circuits have been purged.
- 4 Close purge valve and open all balancing and boiler valves. If mixing station is attached, reset high-limit kit, and reinstall temperature controller or actuator onto 3-way valve.
- 5 Any remaining air pockets in the system will be eliminated through the boiler's automatic air vent after a few hours of constant circulation.

i If the system must be purged again in the future for any reason, the high limit kit must be reopened during purging for full flow.

Initial Balancing

System should be properly purged before balancing is done. Many times it is not possible to design the system using equal circuit lengths, so the system must be balanced in order to ensure proper flow to each circuit on the manifold.

Procedure

To begin balancing, all circuits must be in the closed position.

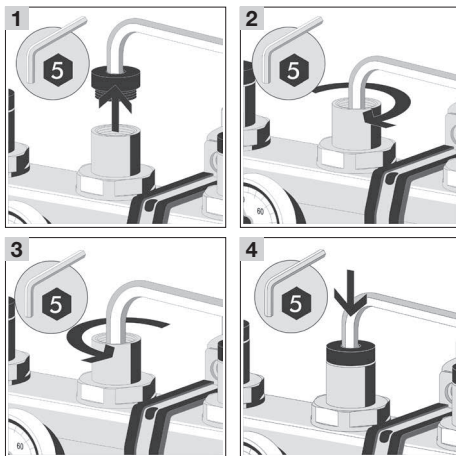

- 1 Use a 5 mm allen wrench (or included valve key) to remove black cap by turning counterclockwise.
- 2 Once black cap is removed, use allen wrench or key to close valve completely by turning clockwise.
- 3 To begin flow, turn allen wrench counterclockwise until desired flow is met.
- 4 Reattach black cap.

i Valve will go from fully closed to fully opened in approximately 5½ turns.



> Viega LLC

585 Interlocken Blvd.
Broomfield, CO 80021

Phone (800) 976-9819
www.viega.us

UG-HC 518857 1119 Stainless Manifold Shut-Off - Balancing (EN)

