

Dimensional Document

Viega MegaPress® CuNi Fittings



This document is subject to updates. For the most current Viega technical literature please visit www.viega.us.



Viega products are designed to be installed by licensed and trained plumbing and mechanical professionals who are familiar with Viega products and their installation. **Installation by non-professionals may void Viega LLC's warranty.**

MegaPress CuNi 90° Elbow P x P - Model 0516

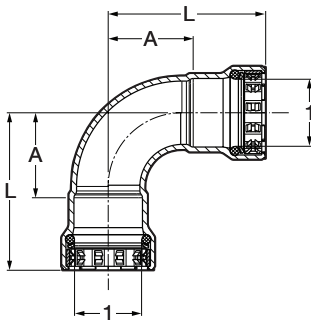

Part No.	Size (in)	A (in)	L (in)
	1		
88000	1/2	1.17	2.24
88005	3/4	1.36	2.52
88010	1	1.72	3.07
88015	1 1/4	2.02	3.84
88020	1 1/2	2.26	4.13
88025	2	2.80	4.76

MegaPress CuNi 90° Elbow P x P - Model 0516XL

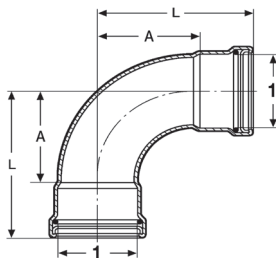

Part No.	Size (in)	A (in)	L (in)
	1		
88030	2 1/2	4.15	5.94
88035	3	4.78	7.09
88040	4	6.00	9.17

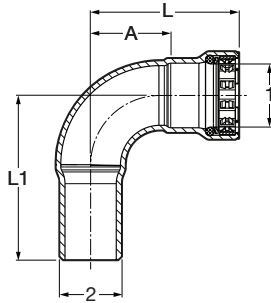
MegaPress CuNi 90° Elbow P x FTG - Model 0516.1

Part No.	Size (in)	A (in)	L (in)	L1 (in)
	1 2			
88045	1/2 x 1/2	1.17	2.24	2.56
88050	3/4 x 3/4	1.36	2.52	2.80
88055	1 x 1	1.72	3.07	3.39
88060	1 1/4 x 1 1/4	2.02	3.84	4.03
88065	1 1/2 x 1 1/2	2.26	4.13	4.21
88070	2 x 2	2.80	4.76	5.08

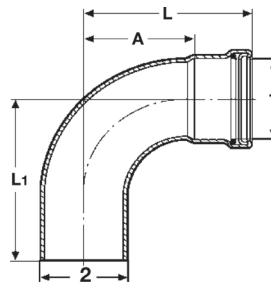
MegaPress CuNi 90° Street Elbow P x FTG - Model 0516.1XL

Part No.	Size (in)	A (in)	L (in)	L1 (in)
	1 2			
88075	2 1/2 x 2 1/2	4.15	5.94	6.06
88080	3 x 3	4.78	7.09	6.81
88085	4 x 4	6.00	9.17	8.78

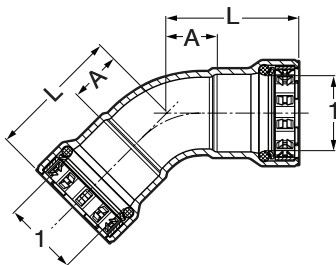
MegaPress CuNi 45° Elbow P x P - Model 0526

Part No.	Size (in)	A (in)	L (in)
	1		
88090	1/2	0.60	1.67
88095	3/4	0.71	1.87
88100	1	0.86	2.20
88105	1 1/4	1.00	2.81
88110	1 1/2	1.12	2.99
88115	2	1.32	3.29

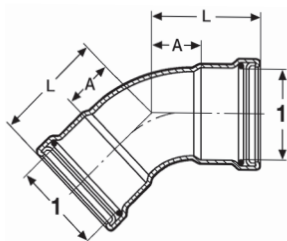
MegaPress CuNi 45° Elbow P x P - Model 0526XL

Part No.	Size (in)	A (in)	L (in)
	1		
88120	2 1/2	2.10	3.90
88125	3	2.26	4.56
88130	4	2.74	5.89

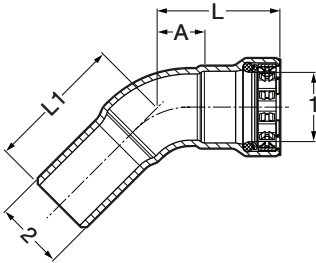
MegaPress CuNi 45° Elbow P x FTG - Model 0526.1

Part No.	Size (in)		A (in)	L (in)	L1 (in)
	1	2			
88135	1/2	1/2	0.60	1.67	1.97
88140	3/4	3/4	0.71	1.87	2.13
88145	1	1	0.86	2.20	2.52
88150	1 1/4	1 1/4	1.00	2.81	3.00
88155	1 1/2	1 1/2	1.12	2.99	3.07
88160	2	2	1.32	3.29	3.58

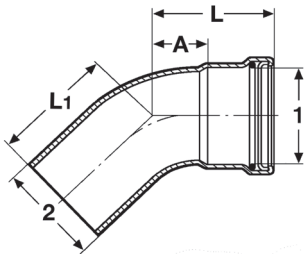
MegaPress CuNi 45° Street Elbow P x FTG - Model 0526.1XL

Part No.	Size (in)		A (in)	L (in)	L1 (in)
	1	2			
88165	2 1/2	2 1/2	2.10	3.90	3.95
88170	3	3	2.26	4.56	4.34
88175	4	4	2.74	5.89	5.62

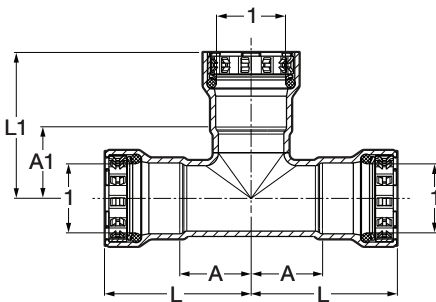
MegaPress CuNi Tee P x P x P - Model 0518

Part No.	Size (in)		A (in)	A1 (in)	L (in)	L1 (in)
	1	2				
88180	1/2	1/2	0.97	0.97	2.04	2.04
88185	3/4	3/4	1.08	1.05	2.23	2.20
88190	1	1	1.23	1.23	2.57	2.57
88195	1 1/4	1 1/4	1.41	1.38	3.23	3.20
88200	1 1/2	1 1/2	1.57	1.57	3.44	3.44
88205	2	2	1.81	1.84	3.78	3.81

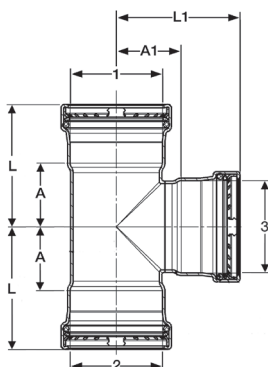
MegaPress CuNi Tee P x P x P - Model 0518XL

Part No.	Size (in)			A (in)	A1 (in)	L (in)	L1 (in)
	1	2	3				
88210	2 1/2	2 1/2	2 1/2	2.16	2.24	3.96	4.04
88250	3	3	2	2.11	2.30	4.41	4.26
88255	3	3	2 1/2	2.32	2.49	4.63	4.29
88215	3	3	3	2.58	2.52	4.88	4.82
88260	4	4	2	2.18	2.87	5.35	4.84
88265	4	4	2 1/2	2.37	3.08	5.55	4.88
88270	4	4	3	2.63	3.09	5.81	5.39
88220	4	4	4	3.22	3.08	6.40	6.26

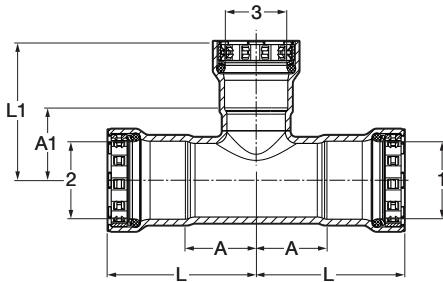
MegaPress CuNi Reducing Tee P x P x P - Model 0518

Part No.	Size (in)			A (in)	A1 (in)	L (in)	L1 (in)
	1	2	3				
88225	1	1	1/2	1.23	1.19	2.57	2.26
88230	1	1	3/4	1.23	1.26	2.57	2.41
88235	2	2	1/2	1.81	1.74	3.78	2.81
88240	2	2	3/4	1.81	1.80	3.78	2.95
88245	2	2	1	1.81	1.81	3.78	3.16

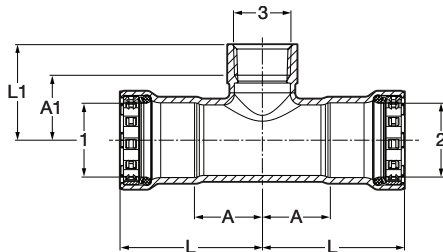
MegaPress CuNi Reducing Tee P x P x FPT - Model 0517.2

Part No.	Size (in)			A (in)	A1 (in)	L (in)	L1 (in)
	1	2	3				
88275	1/2	1/2	1/2	0.97	0.91	2.04	1.45
88280	1	1	1/2	1.23	1.19	2.57	1.73
88285	1	1	3/4	1.23	1.18	2.57	1.73
88290	2	2	1/2	1.81	1.75	3.78	2.28
88295	2	2	3/4	1.81	1.72	3.78	2.28

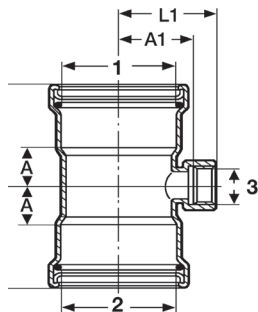
MegaPress CuNi Tee P x P x FPT - Model 0517.2XL

Part No.	Size (in)			A (in)	A1 (in)	L (in)	L1 (in)
	1	2	3				
88300	3	3	1/2	1.44	2.24	3.74	2.78
88305	3	3	3/4	1.44	2.25	3.74	2.78
88310	4	4	1/2	1.45	2.77	4.63	3.28
88315	4	4	3/4	1.55	2.78	4.72	3.34

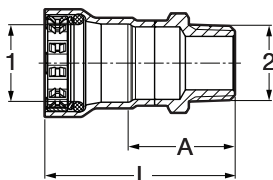
MegaPress CuNi Adapter P x MPT - Model 0511

Part No.	Size (in)		A (in)	L (in)
	1	2		
88320	1/2	1/2	1.46	2.53
88325	3/4	3/4	1.47	2.63
88330	1	1	1.66	3.00
88335	1 1/4	1 1/4	1.89	3.70
88340	1 1/2	1 1/2	1.93	3.80
88345	2	2	1.94	3.91

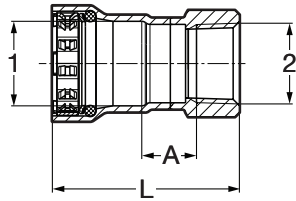
MegaPress CuNi Adapter P x FPT - Model 0512

Part No.	Size (in)	A (in)	L (in)
	1 2		
88350	1/2 x 1/2	0.70	2.31
88355	3/4 x 3/4	0.74	2.40
88360	1 x 1	0.71	2.72
88365	1 1/4 x 1 1/4	0.77	3.27
88370	1 1/2 x 1 1/2	0.73	3.28
88375	2 x 2	0.73	3.42

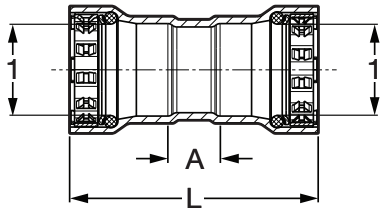
MegaPress CuNi Coupling with Stop P x P - Model 0515

Part No.	Size (in)	A (in)	L (in)
	1		
88380	1/2	0.56	2.70
88385	3/4	0.63	2.94
88390	1	0.59	3.28
88395	1 1/4	0.70	4.34
88400	1 1/2	0.89	4.63
88405	2	0.77	4.71

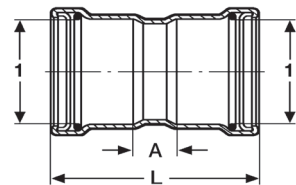
MegaPress CuNi Coupling with Stop P x P - Model 0515XL

Part No.	Size (in)	A (in)	L (in)
	1		
88410	2 1/2	1.32	4.92
88415	3	1.38	5.98
88420	4	1.52	7.87

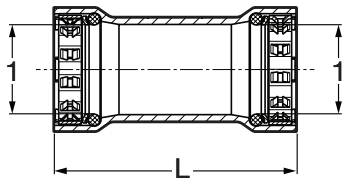
MegaPress CuNi Coupling No Stop P x P - Model 0515.5

Part No.	Size (in)	L (in)
	1	
88425	1/2	2.70
88430	3/4	2.94
88435	1	3.29
88440	1 1/4	4.33
88445	1 1/2	4.63
88450	2	4.71

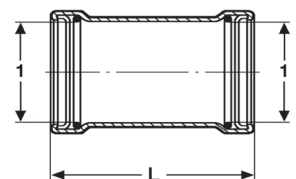
MegaPress CuNi Coupling No Stop P x P - Model 0515.5XL

Part No.	Size (in)	L (in)
	1	
88455	2 1/2	4.92
88460	3	5.98
88465	4	7.87

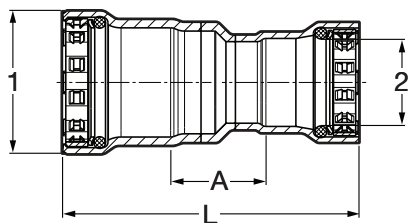
MegaPress CuNi Reducer P x P - Model 0515.2

Part No.	Size (in)	A (in)	L (in)
	1 2		
88470	3/4 x 1/2	1.14	3.37
88475	1 x 1/2	1.34	3.76
88480	1 x 3/4	1.17	3.67
88485	1 1/4 x 3/4	1.28	4.26
88490	1 1/4 x 1	1.21	4.38
88495	1 1/2 x 1	1.35	4.57
88500	1 1/2 x 1 1/4	1.23	4.92
88505	2 x 1 1/4	1.44	5.23
88510	2 x 1 1/2	1.40	5.24

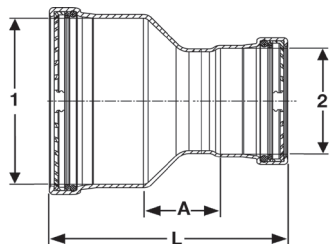
MegaPress CuNi Reducer P x P - Model 0515.2XL

Part No.	Size (in)	A (in)	L (in)
	1 2		
88515	2 1/2 x 1 1/2	2.13	5.80
88520	2 1/2 x 2	1.81	5.58
88525	3 x 2	2.13	6.40
88530	3 x 2 1/2	2.06	6.16
88535	4 x 2 1/2	2.58	7.56
88540	4 x 3	2.33	7.81

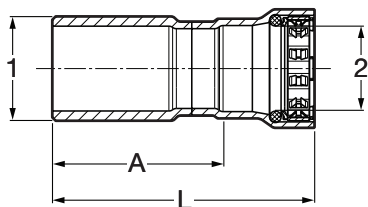
MegaPress CuNi Reducer FTG x P - Model 0515.1

Part No.	Size (in)	A (in)	L (in)
	1 2		
88545	3/4 x 1/2	1.92	2.99
88550	1 x 1/2	2.25	3.32
88555	1 x 3/4	2.18	3.34
88560	1 1/4 x 3/4	2.80	3.96
88565	1 1/4 x 1	2.81	4.15
88570	1 1/2 x 1	2.81	4.15
88575	1 1/2 x 1 1/4	2.80	4.62
88580	2 x 1 1/4	3.18	5.00
88585	2 x 1 1/2	2.97	4.84

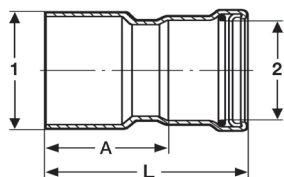
MegaPress CuNi Reducer FTG x P - Model 0515.1XL

Part No.	Size (in)	A (in)	L (in)
	1 2		
88590	2 1/2 x 1 1/2	3.32	5.19
88595	2 1/2 x 2	3.03	5.00
88600	3 x 2	3.80	5.77
88605	3 x 2 1/2	3.77	5.57
88610	4 x 2 1/2	5.25	7.05
88615	4 x 3	5.04	7.34

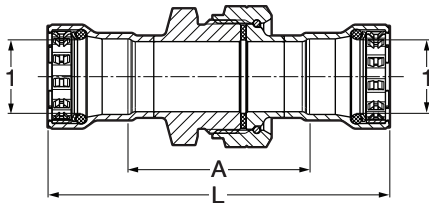
MegaPress CuNi Union P x P - Model 0560

Part No.	Size (in)	A (in)	L (in)
	1		
88620	1/2	2.36	4.50
88625	3/4	2.63	4.94
88630	1	2.61	5.30
88635	1 1/4	2.80	6.44
88640	1 1/2	2.89	6.63
88645	2	3.63	7.56

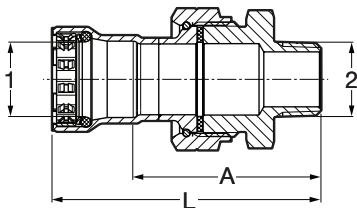
MegaPress CuNi Union P x MPT - Model 0565

Part No.	Size (in)	A (in)	L (in)
	1		
88650	1/2	2.43	3.50
88655	3/4	2.69	3.85
88660	1	2.84	4.19
88665	1 1/4	3.01	4.83
88670	1 1/2	3.10	4.97
88675	2	3.92	5.89

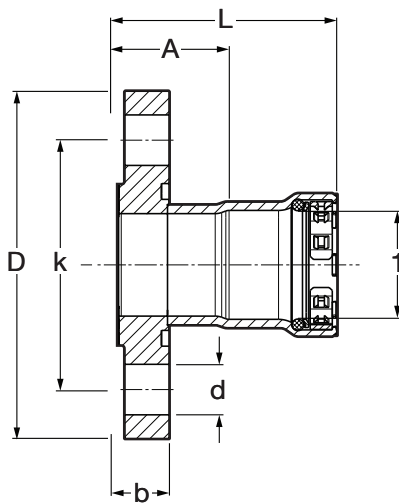
MegaPress CuNi Flange P x BP - Model 0559.5

Part No.	Size (in)	A (in)	L (in)	b (in)	k (in)	D (in)	d (in)
	1						
88680	1	1.38	2.72	0.63	3.11	4.33	0.61
88685	1 1/4	1.39	3.21	0.63	3.50	4.53	0.63
88690	1 1/2	1.48	3.35	0.71	3.86	4.92	0.63
88695	2	1.54	3.51	0.79	4.76	5.91	0.75

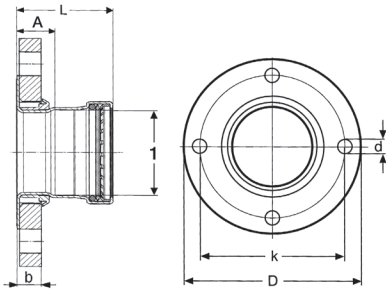
MegaPress CuNi Adapter Flange P - Model 0559XL

Part No.	Size (in)	A (in)	L (in)	b (in)	k (in)	D (in)	d (in)
	1						
88700	2½	1.48	3.28	0.89	5.51	7.09	0.75
88705	3	1.61	3.91	0.96	5.98	7.48	0.75

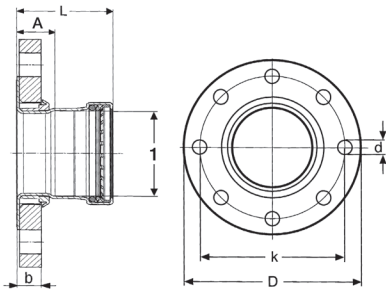
MegaPress CuNi Adapter Flange P - Model 0559XL

Part No.	Size (in)	A (in)	L (in)	b (in)	k (in)	D (in)	d (in)
	1						
88710	4	1.57	4.75	0.96	7.52	9.06	0.75