

Installation Manual

Viega MegaPress® Systems

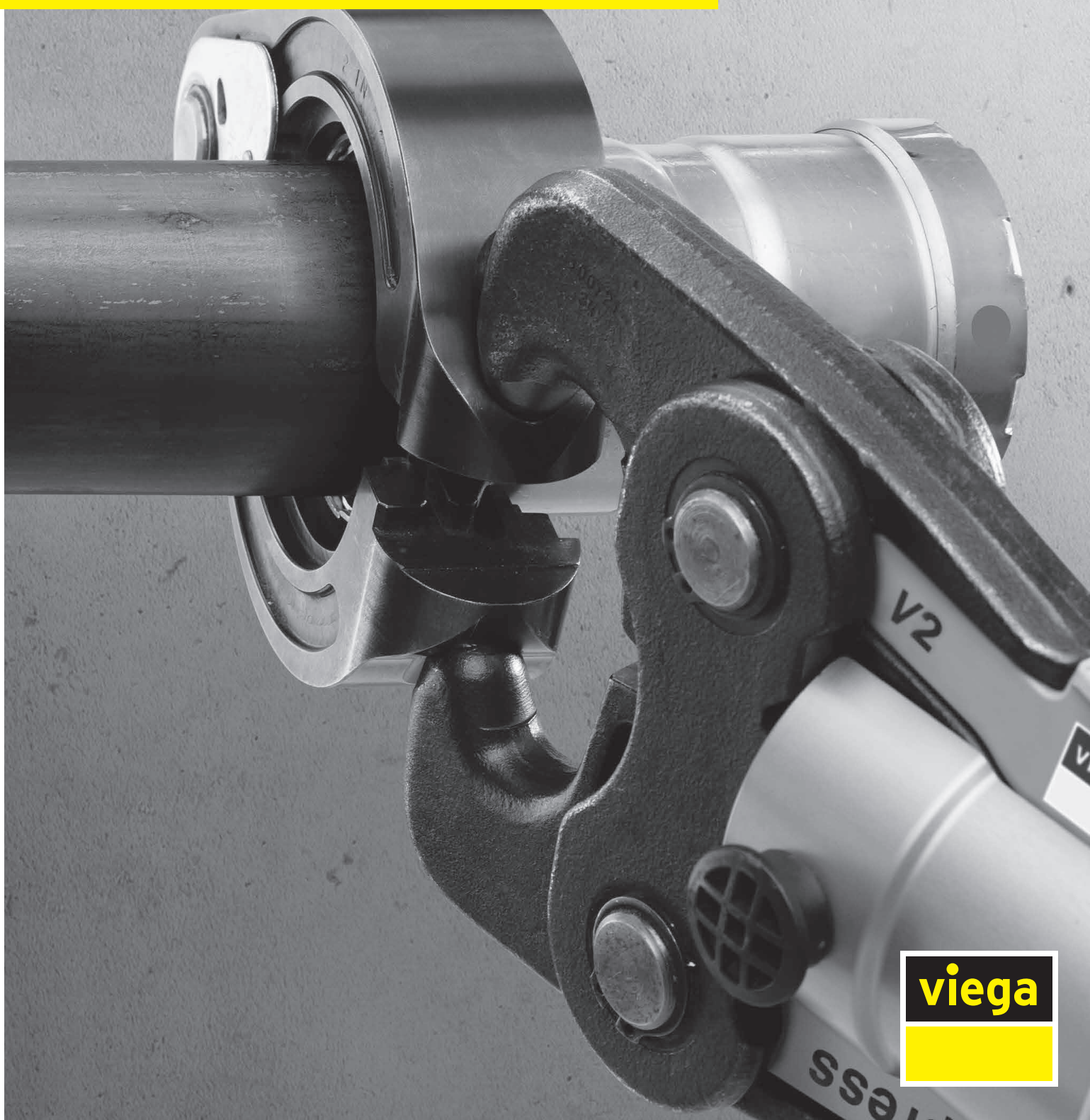

Table of Contents

1	About this Document	6
1.1	Disclaimers	6
1.2	Symbols Used	6
1.3	Audience	7
1.4	About this Version	7
2	Product Information	8
2.1	MegaPress Systems	8
2.2	Safety	8
2.3	Areas of Use	8
2.3.1	MegaPress Systems	9
2.3.2	Fire Protection Systems	10
2.3.3	Technical Assistance	11
2.4	Standards and Regulations	11
2.4.1	Overview	11
2.4.2	Regulations: Applications	11
2.4.3	Standards: Pipes	11
2.4.4	Standards: MegaPressG	11
2.4.5	Standards: Sealing Elements	12
2.4.6	Standards: Pipe Hangers	12
2.4.7	Standards: Pressure Testing	12
2.5	Listings and Certifications	12
2.6	Codes and Standards	13
2.7	Product Description	14
2.7.1	Overview	14
2.7.2	Pipes	14
2.7.2.1	Schedule 5 Pipe	14
2.7.2.2	Schedule 10 Pipe	15
2.7.2.3	Schedule 40 Pipe	15
2.7.3	Press Fittings	15
2.7.3.1	Viega MegaPress ½" to 2" Fittings	15
2.7.3.2	Viega MegaPress 2½" to 4" Fittings	16
2.7.3.3	EPDM Sealing Element	16
2.7.3.4	FKM Sealing Element	16
2.7.3.5	HNBR Sealing Element	17
2.7.3.6	Fitting Markings	17
2.7.3.7	Viega Smart Connect Technology	18
2.8	General Installation Requirements	18
2.8.1	Required Tools	18
2.8.2	Expansion	19
2.8.3	Exposure to Freezing Temperatures	19
2.8.4	Underground Installations	19
2.8.5	Concealed Spaces	20

	2.8.6	Electrical Bonding _____	20
	2.8.7	Corrosion Protection _____	21
	2.8.8	Deflection _____	21
		2.8.8.1 Controlling Deflection _____	22
3		Handling Instructions _____	23
	3.1	Transport _____	23
	3.2	Storage _____	23
	3.3	Pipe Preparation _____	24
4		Installation Instructions _____	25
	4.1	Check System Components _____	25
	4.2	Installing and Mounting the Pipe _____	25
		4.2.1 Pipe Hangers and Supports _____	25
		4.2.2 Transition Fittings _____	26
		4.2.2.1 Threaded Connections _____	26
		4.2.2.2 Flange Connections _____	26
		4.2.3 No-Stop Couplings _____	27
	4.3	Space Requirements and Intervals _____	28
		4.3.1 Minimum Distance Between Fittings _____	28
		4.3.2 Minimum Space Requirements _____	28
		4.3.3 MegaPress Jaws Clearance Requirements _____	29
		4.3.4 MegaPress Rings Clearance Requirements _____	30
		4.3.5 Pressing with Ring and Actuator in Tight Quarters _____	31
	4.4	Welding _____	32
		4.4.1 Welding Adjacent to a Fitting _____	32
		4.4.2 Welding In Line with a Fitting _____	32
		4.4.3 Welding Requirements _____	32
	4.5	Cutting the Pipe _____	32
	4.6	Deburring the Pipe _____	33
	4.7	Pressing the Fitting _____	34
		4.7.1 Viega MegaPress ½" to 2" Installation _____	34
		4.7.2 Viega MegaPress 2½" to 4" Installation _____	37
		4.7.2.1 Using Viega MegaPress XL PressBooster _____	39
		4.7.2.2 Using Viega MegaPress Z3 Actuator _____	40
	4.8	Pressure Testing _____	43
	4.9	Disposal _____	43
5		Limited Warranty _____	44
	5.1	Limited Warranty for Viega MegaPress _____	44
	5.2	Limited Warranty for Viega MegaPressG _____	45
	5.3	Limited Warranty for Viega Metal Systems for Industrial Applications _____	46

List of Tables

Table 1	Applications approved for use with MegaPress systems _____	9
Table 2	Applications regulations _____	11
Table 3	Pipes standards _____	11
Table 4	Sealing elements standards _____	12
Table 5	Mounting standards _____	12
Table 6	Pressure testing standards _____	12
Table 7	Schedule 5 pipe sizing _____	14
Table 8	Schedule 10 pipe sizing _____	15
Table 9	Schedule 40 pipe sizing _____	15
Table 10	Press tools matrix _____	19
Table 11	Pipe hanger spacing _____	26
Table 12	Insertion depths for MegaPress no-stop couplings _____	27
Table 13	Insertion depths for MegaPress extended no-stop couplings _____	27
Table 14	Minimum distance between press fittings _____	28
Table 15	MegaPress distance requirements for press jaws between pipes and walls _____	28
Table 16	MegaPress standard jaws clearance requirements _____	29
Table 17	MegaPress compact jaws clearance requirements _____	29
Table 18	MegaPress standard jaws clearance requirements between pipe, wall, and floor _____	29
Table 19	MegaPress compact jaws clearance requirements between pipe, wall, and floor _____	29
Table 20	MegaPress rings dimensions _____	30
Table 21	MegaPress rings with V2/V3 actuator clearance requirements _____	30
Table 22	MegaPress rings with V2/V3 actuator clearance requirements between pipe, wall, and floor _____	30
Table 23	Minimum insertion depths for MegaPress ½" to 2" _____	34
Table 24	Minimum insertion depths MegaPress 2½" to 4" _____	38

1 About this Document

1.1 Disclaimers



This document is subject to updates. For the most current Viega technical literature, please visit www.viega.us.



Viega products are designed to be installed by licensed and trained plumbing and mechanical professionals who are familiar with Viega products and their installation. **Installation by non-professionals may void Viega LLC's warranty.**

1.2 Symbols Used

The following symbols may be used within this document:



DANGER!

This symbol warns of possible life-threatening injury.



WARNING!

This symbol warns of possible serious injury.



CAUTION!

This symbol warns of possible injury.



NOTICE!

This symbol warns of possible damage to property.



Notes give additional helpful tips.

1.3 Audience

The information in this manual is directed at plumbing and mechanical professionals and trained personnel. Individuals without the above-mentioned training or qualification are not permitted to mount, install and, if required, maintain this product.

1.4 About this Version

This installation manual contains important information about the choice of product or system, assembly, and commissioning as well as intended use and, if required, maintenance measures. The information about the products, their properties, and application technology are based on the current standards in the United States and Canada.

Some passages in the text may refer to technical codes in the United States and Canada. These should serve as recommendations in the absence of corresponding national regulations. The information herein is not binding for other countries and regions; and as mentioned above, should be understood as a recommendation.

2 Product Information

2.1 MegaPress Systems

Viega MegaPress systems are state-of-the-art Iron Pipe Size (IPS) press fitting systems that provides an economical and reliable installation of schedule 5 to schedule 40 carbon steel pipes. The Viega MegaPress fitting system is offered in configurations that allow for the installation of the vast majority of carbon steel piping applications in the residential, commercial, and industrial markets. MegaPress fittings may be used with seamless (S) or longitudinal welded (W) steel pipes.

Viega MegaPress fittings and valves are constructed of carbon steel with a corrosion-resistant zinc/nickel coating ranging from ½ inch to 4 inches.

MegaPress fittings feature a green dot with an EPDM sealing element while MegaPress FKM fittings have a white dot with an FKM sealing element. MegaPressG fittings feature a yellow dot with an HNBR sealing element. All use Viega's unique Smart Connect® technology to help installers ensure that they have pressed all connections.

The Viega MegaPress fitting system requires no welding, soldering, brazing, or threading and poses no fire hazard, which is particularly important in restoration or retrofit work. The fittings are installed with electro-hydraulic press tools (battery-powered or corded press tools).

2.2 Safety

Please read and understand the instructions before beginning installation to eliminate safety concerns and reduce risks associated with use and handling of Viega products.

2.3 Areas of Use

The system is intended for use in industrial, heating and cooling systems and is a replacement for welded, threaded, and rolled-groove connection in new installations and repairs. The system is not suitable for use in potable water installations.



Viega ProPress and MegaPress systems are approved for over 2,500 applications. For information on additional applications to those listed, please contact techsupport@viega.us.

2.3.1 MegaPress Systems

Media ¹	System Operating Conditions			Material and Sealing Element ²		
				MegaPress	MegaPressG	
	Comments	Max Pressure (psig)	Temperature Range (°F)	Carbon Steel		
EPDM ●				FKM ●	HNBR ●	
Water/Liquids						
Chilled Water	≤50% Ethylene / Propylene glycol	200	See note ³	✓	✓	
Hydronic Heating Water ⁹	≤50% Ethylene / Propylene glycol				✓	✓
Isopropyl alcohol			Ambient ⁵	✓	✓	
Fire Sprinkler	NFPA 13, 13D, 13R	175		✓	✓	
Steam	Low pressure	15	Max 250°		✓ ⁴	
	Residential	5	Max 227°	✓ ⁴	✓ ⁴	
Fuels/Oils/Lubricants						
Mineral Oil		200	Ambient ⁵		✓	✓
Lube Oil ¹¹	Petroleum based		Max 150°		✓	✓
Biodiesel ¹¹	ASTM D6751	140			✓	
Propane			-40° to 180°			✓ ⁶
Butane						
Natural Gas	Primarily methane					✓ ⁶
Heating Fuel Oil ¹¹			Max 100°		✓	✓ ¹⁰
Diesel Fuel ¹¹					✓	✓ ¹⁰
Kerosene ¹¹			Max 68°		✓	
Gear Oil	Lubricant	125			✓	✓
Automatic Transmission Fluid						✓
Hydraulic Oil			See note ³		✓	✓ ⁸
Engine Oil					✓	✓ ^{8, 10}
Engine Coolant				✓	✓	
Waste Oil					✓	✓ ^{8, 10}
Gases						
Compressed Air	Oil Concentration ≤25 mg/m ³	200	Max 140°	✓ ⁴	✓ ⁴	✓ ⁴
	Oil Concentration >25 mg/m ³				✓ ⁴	✓ ⁴
Nitrogen - N ₂				✓	✓	✓
Carbon Dioxide - CO ₂	Dry			✓	✓	✓
Argon - Ar				✓	✓	✓
Ammonia	Ammonia environment ⁷		Max 120°	✓	✓	✓
Oxygen - O ₂	Non-medical Keep free of oil and grease	140	Max 140°	✓		
Hydrogen - H ₂		125		✓	✓	✓
Acetylene	Test pressure 350 psi	20	Ambient ⁵	✓	✓	✓
Vacuum	Minimum absolute pressure	750µm Hg	Max 160°	✓	✓	✓
	Maximum differential pressure	29.2" Hg				

¹ It is recommended that all systems be clearly labeled with the media being conveyed. For further information please consult Viega Technical Services.

² All Viega systems must be used with the manufacturer's recommended sealing element. Contact your local Viega representative or Viega Technical Services for specific application temperature, pressure, and concentration limits.

³ System pressure and temperature ranges depend on sealing element. Any ranges listed above will be overruled by the sealing element limits here:

^{3a} EPDM temperature ranges are typically 0°F to 250°F.

^{3b} FKM temperature ranges are typically 14°F to 284°F with temperature spikes (24 hours) up to 356°F.

^{3c} HNBR temperature ranges are typically -40°F to 180°F.

⁴ System must contain adequate condensate drainage.

⁵ Ambient temperatures should be taken as normal operating conditions for the applications not to exceed sealing element limitations.

⁶ Compliant with CSA 6.32 / ANSI LC-4.

⁷ All copper or copper alloy components that are exposed in ammonia environments require lacquer or paint coating.

⁸ HNBR sealing elements are not recommended for silicone based oils.

⁹ It is a Viega engineering best practice that for heating applications using EPDM, where the media will be running continuously, non-stop at 200°F or above, to consider switching to an FKM sealing element.

¹⁰ MegaPressG fittings with HNBR sealing elements are compliant with standard UL 180 for combustible liquid applications.

¹¹ Not approved for use in Canada.

Table 1: Applications approved for use with MegaPress systems

The MegaPressG system is intended for use in natural gas, lubricants/oils, fuel oils, and compressed air systems and is a replacement for welded, threaded, and rolled-groove connection in new installations and repairs. The system is not suitable for use in potable water installations. MegaPressG fittings are for use with fuel gases and are intended for the operating pressure 0-125 psi.



MegaPressG:

The installation, inspection, testing, and purging of the fuel gas system shall be in accordance with local codes or, in the absence of local codes, in accordance with the International Fuel Gas Code, NFPA 54/National Fuel Gas Code z223.1, the Uniform Plumbing Code, NFPA 58, or CSA B 149.1, as applicable.



CAUTION!

MegaPressG fittings are for use with fuel gases and are intended for operating pressures of 0-125 psi.

It is recommended that all systems be clearly labeled with the fluid or gas being conveyed. In the absence of local requirements, systems should be identified in accordance with ANSI/ASME A13.1.



The use of the system for applications other than those listed or outside of these parameters must be approved by Viega Technical Support.

2.3.2 Fire Protection Systems

MegaPress system components may be installed in NFPA 13, 13R, and 13D fire sprinkler systems. They are certified for use in “wet” and “dry” fire protection systems in accordance with UL and FM certifications:

- ANSI/CAN/UL 213: Standard for Rubber Gasketed Fittings for Fire-Protection Services.
- FM Class 1920: Pipe Couplings and Fittings for Aboveground Fire-Protection Systems.

Permitted pressure: 175psi

Pipe wall thickness: Schedule 5 to Schedule 40

Area of use (pipeline network):

Wet sprinkler units: Piping network downstream of the alarm valve station.

Dry sprinkler units: Piping network downstream of the alarm valve station.

Firefighting water additive: Generally not permitted; exceptions only with the manufacturer's permission and prior agreement of Viega Technical Support.



Only black, galvanized, or powder-coated steel pipes may be used in sprinkler systems in accordance to the approved specifications from Viega Technical Support.

2.3.3 Technical Assistance

Consult Viega’s Customer Success Division for information on applications not listed or applications outside listed temperature and pressure ranges.

- Viega Technical Support: techsupport@viega.us
- Engineering Services: For more information on fire protection system design, radiant system design, and plumbing design services: engineeringservices@viega.us

2.4 Standards and Regulations

2.4.1 Overview

The following standards and regulations apply to the United States and Canada and are provided as a support feature.

2.4.2 Regulations: Applications

Scope / Notice	Regulations Applicable in U.S./Canada
Application for fuel gases	MegaPressG only - CSA LC-4
Application in fire extinguishing systems	NFPA 13, 13D, and 13R
Hydronic heating and cooling	ICC LC1002

Table 2: Applications regulations

2.4.3 Standards: Pipes

Standard	Definition
ASTM A53	Standard specifications for steel, black and hot dipped, zinc-coated, welded, or seamless pipe
ASTM A106	Standard specification for seamless carbon steel pipe for high-temperature service
ASTM A135	Standard specification for electric-resistance-welded steel pipe
ASTM A795	Standard specification for black and hot-dipped zinc-coated (galvanized) welded and seamless steel pipe for fire protection
ASME B36.10	Welded and seamless wrought steel pipe

Table 3: Pipes standards

2.4.4 Standards: MegaPressG

- Fuel gas applications shall conform to ASTM A53 and A106 Schedule 10 to 40 carbon steel pipe.
- Non-fuel gas application shall conform to ASTM A53, A106, A135, and A795 Schedule 5 to Schedule 40 carbon steel pipe. Schedule 80 pipe may be used but operating pressures are limited to the Viega Approved Applications guide.
- Carbon steel pipe shall conform to ASTM A53. Pipe schedule (pipe wall thickness) shall conform to the standard referenced dimensions for Schedule 10 or Schedule 40. Adopted code versions, standards compliance, and local approvals should be considered.



MegaPressG

ANSI/CAN/UL/ULC 180 Standard for Safety for Combustible Liquid Tank Accessories: Compression Fittings for Aboveground Pipe Supply and Fill Vents. Install according to the Manufacturer's Instructions. For Combustible Liquid Use. Pressure rating max 125 psi / 861 kPa. Fire rating 30 minutes.



The use of the system for applications other than those listed or outside of these parameters must be approved by the Viega Technical Services Department.

2.4.5 Standards: Sealing Elements

Standard	Definition
ASTM D2000	Classification system for rubber products in automotive applications
ASTM F1476	Performance of gasketed mechanical couplings for use in piping applications

Table 4: Sealing elements standards

2.4.6 Standards: Pipe Hangers

Standard	Definition
MSS SP 58	Pipe hangers and supports materials, design, and manufacturer

Table 5: Mounting standards

2.4.7 Standards: Pressure Testing

Standard	Definition
ASME B31	Pressure piping
IAPMO/ANSI/ CAN Z1117	Press and nail connections
ASTM F3226	Standard specification for metallic press-connect fittings for piping and tubing systems
IACS	Requirements concerning pipes and pressure vessels

Table 6: Pressure testing standards

2.5 Listings and Certifications

MegaPress, MegaPress FKM, and MegaPress G fittings have the following listings and certifications:

- ABS: American Bureau of Shipping Type Approval
- BV: Bureau Veritas Type Approval
- Canadian Registration Number (CRN): 23019.5 A/B/C
- DNV GL: Det Norske Veritas Germanischer Lloyd Type Approval
- LR: Lloyd's Register Type Approval

MegaPress and MegaPress FKM fittings have the following listings and certifications:

- FM Class 1920: Pipe Couplings and Fittings for Aboveground Fire Protection Systems
- IAPMO/ANSI/CAN Z1117: Press and Nail Connections
- ICC-ES LC1002: Press-Connection Fittings for Potable Water Tube and Radian Heating Systems
- ANSI/CAN/UL 213: Standard for Rubber Gasketed Fittings for Fire-Protection Service

MegaPressG fittings have the following listings and certifications:

- ANSI/CAN/UL/ULC 180: Standard for Safety for Combustible Liquid Tank Accessories
- CSA: ANSI LC 4a/CSA 6.32a: Press-Connect Metallic Fittings for Use in Fuel Gas Distribution Systems
- IAPMO: ANSI LC 4a/CSA 6.32a: Press-Connect Metallic Fittings for Use in Fuel Gas Distribution Systems
- ICC-ES: ANSI LC 4a/CSA 6.32a: Press-Connect Metallic Fittings for Use in Fuel Gas Distribution Systems

2.6 Codes and Standards



It is the responsibility of the installer or any other parties to adhere to all applicable local rules and regulations governing the nature of the installation.

MegaPress, MegaPress FKM, and MegaPressG fittings comply with the following codes and standards:

- ASME B31: Code for Pressure Piping
- ASME B31.1: Power Piping
- ASME B31.3: Process Piping
- ASME B31.9: Building Service Piping
- IAPMO Uniform Mechanical Code (UMC)
- ICC International Mechanical Code (IMC)
- ICC International Residential Code (IRC)
- National Building Code of Canada (NBCC)
- National Plumbing Code of Canada (NPCC)

MegaPress and MegaPress FKM comply with the following codes and standards:

- NFPA 13: Standard for the Installation of Sprinkler Systems
- NFPA 13D: Standard for the Installation of Sprinkler Systems in One- and Two-Family Dwellings and Manufactured Homes
- NFPA 13R: Standard for the Installation of Sprinkler Systems in Low-Rise Residential Occupancies

MegaPressG fittings comply with the following codes and standards:

- CAN/CSA-B149.1: Natural Gas and Propane Installation Code
- IAPMO National Standard Plumbing Code (NSPC)
- IAPMO Uniform Plumbing Code (UPC)
- ICC International Fuel Gas Code (IFGC)
- NFPA 54/Z223: National Fuel Gas Code
- NFPA 58: Liquefied Petroleum Gas Code

2.7 Product Description

2.7.1 Overview

The MegaPress system consists of press connectors for heavy steel pipes and the corresponding press tools. MegaPress press jaws, actuator, and rings are available for various dimensions. Their constant compression produces a positive, nondetachable, mechanical joint. The system components are available in the following dimensions: ½", ¾", 1", 1¼", 1½", 2", 2½", 3", 4".

2.7.2 Pipes

MegaPress connectors may be used with the following seamless or longitudinal welded steel pipes:

- Black
- Galvanized (non-potable applications)
- Industrially painted
- Powder coated

Viega MegaPress systems are compatible with ASTM A53, A135, A106, and A795 Schedule 5 to Schedule 40 carbon steel pipe. Viega MegaPressG fittings for fuel gas or fuel oil systems shall be used with ASTM A53 schedule 10 to schedule 40 carbon steel pipe.



If the pipe has been coated, the maximum external diameter listed in the following tables must not be exceeded.

2.7.2.1 Schedule 5 Pipe

Pipe Size (in)	Outside diameter (in)	Outside diameter (mm)	Wall thickness (in)	Wall thickness (mm)
½	0.84	21.3	0.065	1.65
¾	1.05	26.7	0.065	1.65
1	1.32	33.4	0.065	1.65
1¼	1.66	42.2	0.065	1.65
1½	1.9	48.3	0.065	1.65
2	2.375	60.3	0.065	1.65
2½	2.875	73.0	0.083	2.11
3	3.5	88.9	0.083	2.11
4	4.5	114.3	0.083	2.11

Table 7: Schedule 5 pipe sizing

2.7.2.2 Schedule 10 Pipe

Pipe Size (in)	Outside diameter (in)	Outside diameter (mm)	Wall thickness (in)	Wall thickness (mm)
½	0.84	21.3	0.083	2.11
¾	1.05	26.7	0.083	2.11
1	1.32	33.4	0.109	2.77
1¼	1.66	42.2	0.109	2.77
1½	1.9	48.3	0.109	2.77
2	2.375	60.3	0.109	2.77
2½	2.875	73.0	0.12	3.05
3	3.5	88.9	0.12	3.05
4	4.5	114.3	0.12	3.05

Table 8: Schedule 10 pipe sizing

2.7.2.3 Schedule 40 Pipe

Pipe Size (in)	Outside diameter (in)	Outside diameter (mm)	Wall thickness (in)	Wall thickness (mm)
½	0.84	21.3	0.109	2.77
¾	1.05	26.7	0.113	2.87
1	1.32	33.4	0.133	3.38
1¼	1.66	42.2	0.14	3.56
1½	1.9	48.3	0.145	3.68
2	2.375	60.3	0.154	3.91
2½	2.875	73.0	0.203	5.16
3	3.5	88.9	0.216	5.49
4	4.5	114.3	0.237	6.02

Table 9: Schedule 40 pipe sizing

2.7.3 Press Fittings

Press fittings are available in a number of configurations and sizes. An overview of the press fittings suitable for a system can be found in the catalog.

2.7.3.1 Viega MegaPress ½" to 2" Fittings

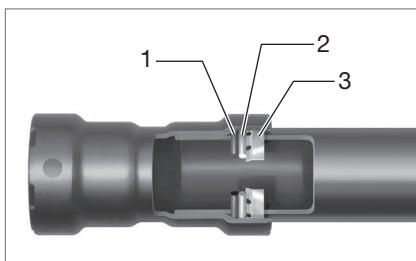

- 1 Each fitting contains an application specific sealing element.
- 2 The 304 stainless steel separator ring ensures that the sealing element and grip ring perform at maximum capacity by providing a positive physical separation.
- 3 The grip ring is a 420 stainless steel ring with bidirectional teeth that grip the pipe and ensure that the fitting is locked securely to the piping.

2.7.3.2 Viega MegaPress 2½" to 4" Fittings

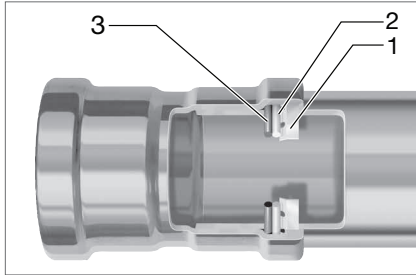

- 1 The 420 stainless steel grip ring's teeth cut into the pipe and lock the fitting securely in place.
- 2 A PBT (Polybutylene Terephthalate) separator ring for MegaPress and MegaPress FKM fittings and a graphite separator ring for MegaPressG fittings protects the sealing element from damage by creating a positive physical separation during installation and later during pressing.
- 3 The sealing element ensures watertight or airtight connections.

2.7.3.3 EPDM Sealing Element



Viega MegaPress fittings are manufactured with a high-quality, shiny black EPDM (Ethylene Propylene Diene Monomer) sealing element installed at the factory. Sealing elements are inserted into the fitting using a H1 food grade lubricant registered with NSF and the USDA, and is approved for use under FDA 21 CFR.

The EPDM sealing element possesses excellent resistance to aging, ozone, sunlight, weathering, environmental influences, and most alkaline solutions and chemicals used in a broad range of applications.

The operating temperature of the EPDM sealing element is 0° to 250°F (-18° to 120°C).

2.7.3.4 FKM Sealing Element



Viega MegaPress FKM fittings are manufactured with a high-quality, dull black FKM (Fluoroelastomer) sealing element installed at the factory. Sealing elements are inserted into the fitting using a H1 food grade lubricant registered with NSF and the USDA, and is approved for use under FDA 21 CFR.

FKM possesses excellent resistance to aging, ozone, sunlight, weathering, environmental influences, and oils and petroleum-based additives. Its superb resistance to high temperatures and petroleum based additives makes it ideal for seals and gaskets in solar, district heating, low-pressure steam, and compressed air system fittings.

The operating temperature of the FKM sealing element is 14° to 284°F (-10° to 140°C). It can withstand heat spikes up to 356°F.

2.7.3.5 HNBR Sealing Element



Viega MegaPressG fittings are manufactured with a yellow HNBR (Hydrogenated Nitrile Butadiene Rubber) sealing element installed at the factory. HNBR is widely known for its physical strength and retention of properties after long-term exposure to heat, oil, and chemicals.

The unique properties attributed to HNBR have resulted in wide adoption of HNBR in automotive, industrial, and assorted high-performance applications. Sealing elements are inserted into the fitting using a H1 food grade lubricant registered with NSF and the USDA, and is approved for use under FDA 21 CFR.

The operating temperature of the HNBR sealing element is -40°F to 180°F (-40°C to 82°C).

2.7.3.6 Fitting Markings

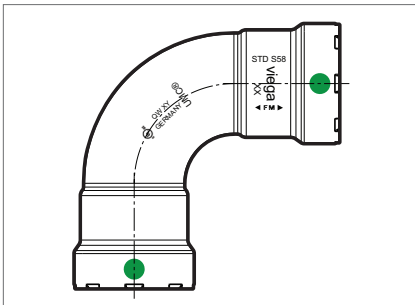

Each MegaPress fitting is marked with the following:

- Green dot: EPDM sealing element and Smart Connect technology
- Size of fitting
- Manufacturer name
- Manufacturer date code
- Country of origin
- UMC®
- UL®
- FM
- STD S58

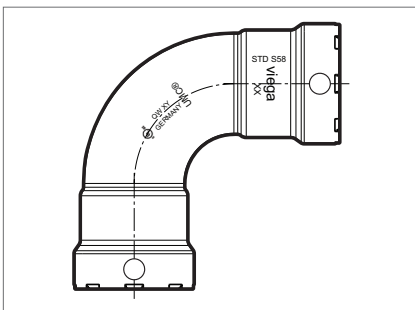

Each MegaPress FKM fitting is marked with the following:

- White dot: FKM sealing element and Smart Connect technology
- Size of fitting
- Manufacturer name
- Manufacturer date code
- Country of origin
- UMC®
- UL®
- STD S58

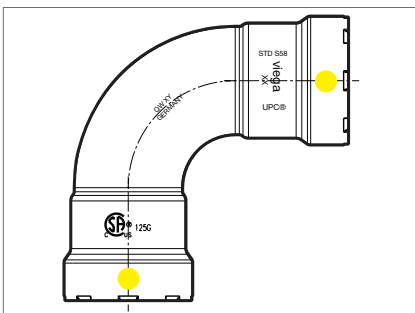

Each MegaPressG fitting is marked with the following:

- Yellow dot: HNBR sealing element and Smart Connect technology
- Yellow rectangle: identifies Viega MegaPressG fitting as a certified gas or fuel oil fitting
- Size of fitting
- Manufacturer name
- Manufacturer date code
- Country of origin
- UPC®
- CSA: indicates certification to ANSI/CSA LC4
- 125G: identifies the CSA maximum pressure rating of the fitting for fuel oil or gas applications

2.7.3.7 Viega Smart Connect Technology



1 Identify an unpressed connection during pressure testing when water flows past the sealing element.

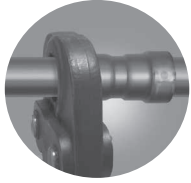

2 Upon identification, use the press tool to press the fitting, making a secure leak-proof connection.

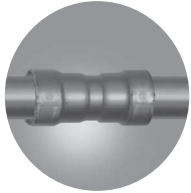

3 Viega MegaPress connections are fast, flameless, and reliable.

Viega Smart Connect technology provides the installer quick and easy identification of an unpressed fitting during a leak test. When the fitting is pressed, a secure, non-detachable, mechanical connection is created. Smart Connect technology provides the installer with an easy way to see connections that have not been pressed before putting the system into operation.



Testing for leaks using Viega Smart Connect is not a replacement for testing requirements of local codes and standards. If testing with compressed air, it is necessary to use an approved leak-detect solution.

2.8 General Installation Requirements

The Viega MegaPress fitting system must be installed while considering the following general industry requirements.

2.8.1 Required Tools

The following tools are required for making a press connection:

- Pipe cutter or a fine-toothed hacksaw
- Deburring tool
- Marker for marking insertion depth on pipe
- Press machine with constant pressing force
- Press jaw or press ring with corresponding actuator or booster suitable for the pipe diameter and with the proper profile



Improper Tool/Material Damage

Only use press jaws and rings that are designed for use with MegaPress fittings.

Tool	Attachments	MegaPress Sizes (in)
Viega Pressgun 6	Standard Jaws	½ - 1
	V1 Actuator and Rings	
	V2 Actuator and Rings	1¼ - 2
Viega Pressgun Picco 6	Compact Jaws	½ - ¾
	C1 Actuator and Rings	½ - 1¼
RIDGID 330/340/350	Standard Jaws	½ - 1
	V2 Actuator and Rings	1¼ - 2
	MegaPress XL PressBooster	2½ - 4
RIDGID 240/241	Compact Jaws	½ - 1
	C1 Actuator and Rings	½ - 1¼
RIDGID RP 342-XL	Standard Jaws	½ - 1
	V2 Actuator and Rings	1¼ - 2
	Z3 Actuator and Rings	2½ - 4
Milwaukee M12 Force Logic	M12 Jaws	½ - 1
Milwaukee M18 Force Logic	M18 Jaws	½ - 1
	M18 Rings	1¼ - 2
Milwaukee M18 Long Throw	M18 Jaws	½ - 1
	M18 Rings	1¼ - 2
	Z3 Actuator and Rings	2½ - 4

Table 10: Press tools matrix

2.8.2 Expansion

Pipelines expand with heat. Heat expansion is dependent on the material. Thermal expansion in installed systems generates stress on pipes and appliance connectors. Compensation must be allowed for expansion and contraction that may occur within the piping system. Expansion joints or mechanical expansion compensators may be used to alleviate these stresses.

The following methods are effective:

- Fixed and sliding hangers
- Expansion equalization joints (expansion bends)
- Expansion compensators

2.8.3 Exposure to Freezing Temperatures

Viega MegaPress systems with EPDM sealing elements can be installed in ambient temperatures down to 0° F. Viega MegaPress FKM systems with FKM sealing elements can be installed in ambient temperatures down to 14°F. The HNBR sealing element available with Viega MegaPressG fittings can be installed in ambient temperatures down to -40°F.

Piping systems exposed to freezing temperatures must be protected per acceptable engineering practices, codes, and as required by the local authority.

2.8.4 Underground Installations

Viega MegaPress fitting systems are all approved for underground installations. However, installations must meet all state and local codes, including those for underground. Proper authorization must be obtained prior to installation from the local authority.

2.8.5 Concealed Spaces

The Viega MegaPress fitting system has been approved for use in concealed spaces. Specific performance tests were conducted to evaluate the fittings for use in concealed spaces. Concealed tubing and fittings shall be protected from puncture threats.

The Viega MegaPressG fitting system has been examined according to the construction and performance criteria in the CSA requirement LC-4 and was found acceptable. Specific performance tests were conducted to evaluate the fittings for use in concealed locations.

2.8.6 Electrical Bonding

When properly installed, MegaPress fittings comply with Section 1211.15 Electrical Bonding and Grounding of the Uniform Plumbing Code.

The mechanical press provides continuous metal-to-metal contact between fitting and pipe. The press ensures the continuity of the bonding through this contact.



A qualified electrician is responsible for ensuring electrical bonding is tested and secured.



DANGER! **Electric Shock**

An electric shock can cause burns, serious injury, and even death.

- Because all metallic piping can conduct electricity, unintentional contact with a live wire can cause the entire system and components connected to it to become energized. Metal piping is not meant to conduct electricity.
- A properly bonded system creates a safe path for electricity to travel so that the system can't be energized.
- An unbonded or improperly bonded system can be a shock hazard.
- Always ensure bonding is in accordance with local codes.



CAUTION! **Potential explosive hazard – MegaPressG**

The fuel gas system shall not be used as a grounding electrode for an electrical system.



CAUTION!

Pressure and electrical grounding

- The fittings are for use with fuel gases and are intended for the operating pressure 0-125 psi.
- The fuel gas system shall not be used as a grounding electrode for an electrical system.

2.8.7 Corrosion Protection

Viega MegaPress fittings exposed to corrosive action, such as soil conditions or moisture, must be protected in an approved manner in accordance with NFPA 54 Section 404.8, NACE Standard RP0169-2002 Section 5, 2009 UPC Chapter 6 Section 609.3.1, 2009 UMC Chapter 13 Section 1312.1.3, or satisfying local code requirements.

Care should be taken to select hangers of suitable material that is galvanically compatible with the piping system. In addition, systems should be properly sized to minimize the risk of erosion corrosion resulting from excessive velocities.

In some cases the local authority may require pipe and fittings to be painted. Installers should use caution to prevent saturating the fittings with paint and take care to not allow excess paint to accumulate on the fitting hub. Failure to use caution could result in a premature failure.

2.8.8 Deflection

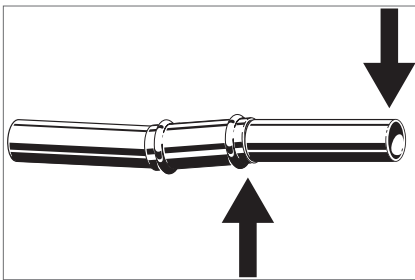

The pressing process can cause deflection (angular misalignment) to occur. When pressing Viega MegaPress fittings in a system, the deformation of the fitting is constant. This allows for a consistent leak-free joint every time and is a result of the pressing technique.

Deflection occurs in the same way for every fitting. The fitting being pressed will move in the direction of the jaw or ring opening.

- Since the fitting will deflect toward the opening of the jaw or ring, the pipe end will deflect in the opposite direction.
- By counteracting the fitting movement, one can minimize the deflection of the fitting and ultimately the pipe.
- When using strut and clamps, deflection is minimized and nearly eliminated depending on clamp spacing.

2.8.8.1 Controlling Deflection

Deflection while pressing can be minimized by utilizing the following installation practices.

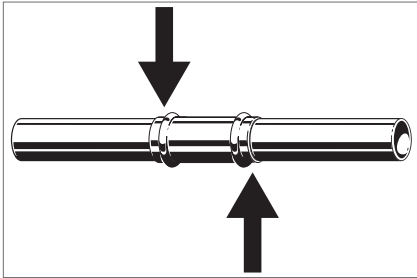

Alternate Press Directions

- Press one end of fitting.
- Make second press on other end of fitting from the opposite side. Site conditions permitting.

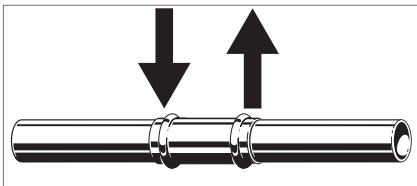

Push-Pull Method

- Rings = Push on press tool.
 - Jaws = Pull on press tool.
- The press tool can be feathered using the trigger as needed to apply pulling or pushing force to control deflection.

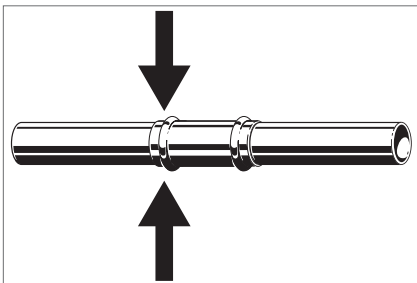

Re-Press

- Press the fitting, once on each side (that is, re-press the fitting a second time on the opposite side). Pressing the same connection from the opposite side will usually straighten misalignment between the pipe and fitting.

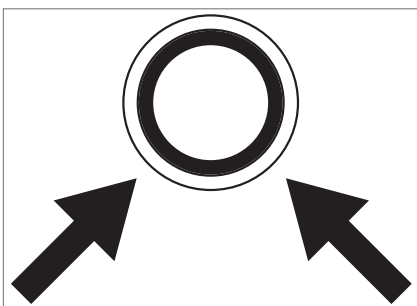

- When pressing overhead piping, it may be inconvenient to alternate sides for each press.
- The natural weight of the piping plus pressing on opposite sides at a 45 degree angle should adequately eliminate deflection.
- This technique can also be used for any horizontal piping and also when working above the piping.



- As long as the pipe is properly prepped and marked and the fitting is installed according to Viega's MegaPress Product Instructions, if there is any deflection present after the installation of the fitting, the connection is still acceptable and meets Viega's manufacturing specifications for proper installation and warranty.
- Deflection of a press connection has no effect on the integrity of the system, and it can be pressure tested in accordance with the MegaPress Product Instructions.

3 Handling Instructions

All Viega MegaPress components and associated pipe shall be free from dirt, debris, or items that may interfere with the sealing element and the press connection. Viega MegaPress sealing elements, separator rings, and grip rings are to be visually inspected prior to installation to ensure the seal is intact and properly located within the fitting. Viega MegaPress sealing elements, separator rings, and grip rings are not interchangeable between the different MegaPress systems.

3.1 Transport

When transporting fittings:







- Do not pull or drag the fittings or system components along other surfaces.
- Secure fittings, piping, and system components during transportation to keep them from shifting.
- Do not damage the protective cap on components or pipe ends.
- Do not remove protective caps until immediately before installing.

3.2 Storage

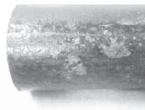
When storing materials:

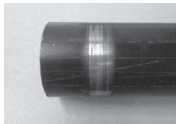
- Store fittings, pipe, and system components in a clean and dry place.
- Do not store components directly on the floor.
- Provide at least three points of support for the storage of piping.
- Where possible, store different sizes separately.
- Store small sizes on top of larger sizes if separate storage is not possible.
- Store fittings, pipe, and system components of different materials separately to prevent contact corrosion.

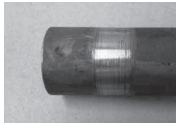
3.3 Pipe Preparation

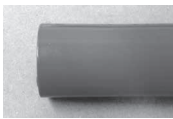
Description	Different kinds of pipe surface	Prep necessary Yes / No	Surface after prepping	Comments
Clean, bare pipe		No		If the pipe has no lacquer and there is no rust on the surface and the surface is smooth, no preparing is necessary.
Galvanized steel pipe		Yes		If the surface of the galvanized pipe is uneven, then the pipe surface must be smoothed.
Pipe with black shellac or lacquer		Yes		If the pipe is coated with black shellac or lacquer the coating has to be smoothed. It is not necessary to completely remove the coating.
Pipe with rust		Yes		If the pipe has no lacquer and there is a rust film on the surface, the surface has to be prepped until the rust film is removed and the pipe surface is smooth.
Epoxy coating		No		The epoxy coating must be reduced to allow the pipe to be inserted into the fitting. If the pipe has been coated, the maximum external diameter must not exceed the limit in the Insertion Depth table.
Cataphoretic paint (KTL)		No		If the pipe is cataphoretic painted (KTL) and the surface is smooth, it is not necessary to prep the pipe. If there are scratches on the KTL, the surface has to be smoothed.

Pipe surfaces for each type of pipe must be smooth, free of indentations (even and undamaged), pits, and deformations, and must be clean and free of dirt, debris, rust, scale, oil, and grease. It is not necessary to completely remove protective coatings or to expose the bare steel material.

Install MegaPress fittings on plain end pipe only. Pressing fittings directly over threads will result in an improper seal.

To avoid leak paths, engraved or stamped pipe shall not be used with the Viega MegaPress fitting system. Engraving or stamping shall not be removed through use of a grinder or other tool.

In systems where complete corrosion protection is required (e.g., cooling systems), apply suitable corrosion protection to the previously processed pipe surfaces that are still uncovered after pressing.

The Viega MegaPress system does not require lubrication of the pipe or the fitting.

4 Installation Instructions

4.1 Check System Components

System components may, in some cases, become damaged through transportation and storage.

- Check all parts.
- Replace damaged components.
- Do not repair damaged components.
- Contaminated components may not be installed.

4.2 Installing and Mounting the Pipe

Observe the general rules of hanging and mounting:

- Fixed piping should not be used as support for other piping and components.
- Do not use pipe hooks.
- Observe distance between fittings and mounting points.
- Observe the expansion direction – plan fixed and sliding mounts.

4.2.1 Pipe Hangers and Supports

Piping supports perform two functions:

- To provide support for the piping.
- To guide the pipe during thermal expansion and contraction.



Fittings must not be used as support

- System malfunction may result from additional stress and strain put on the fitting.
- At no point in the system should a fitting be the sole means of support. For example, when installing a tee, both the branch and the trunk must be properly supported.

Industry standard practices and guidelines shall be used for pipe layout and support. Supports, hangers, and anchors are to be installed in a manner that does not interfere with the free expansion and contraction of the piping. All parts of the support equipment need to be designed and installed to not disengage due to movement of the supported piping. Sliding hangers must be positioned so that they cannot unintentionally become rigid hangers when the system is in use.

- Do not use fixed pipelines as a support for other pipelines and components.
- Do not use pipe hooks.
- Observe the expansion direction: plan fixed and gliding points.

Hangers and supports must conform to the local code requirements. In the absence of local code requirements, hangers and supports should conform to ANSI/MSS SP 58 Pipe Hangers and Supports - Materials, Design, Manufacture, Selection, Application and Installation. Only pipe clamps with chloride-free noise insulation inlays should be used to secure the pipes.

Pipe Size (in)	Maximum Span (feet)	Minimum Rod Diameter (in)
1/2	7	3/8
3/4		
1		
1 1/4		
1 1/2	9	3/8
2	10	3/8
2 1/2	11	1/2
3	12	1/2
4	14	1/2

Table 11: Pipe hanger spacing

4.2.2 Transition Fittings

4.2.2.1 Threaded Connections

The Viega MegaPress systems can be joined with off-the-shelf threaded fittings. In this regard:

- The threaded connection is made first.
- The press connection is made second.

This process avoids unnecessary torsion on the press fitting.

4.2.2.2 Flange Connections

When using Viega flanges, bolt the flange end in place prior to pressing the fitting to the pipe.

4.2.3 No-Stop Couplings

No-stop couplings and extended no-stop couplings are often used to conduct repairs. Without a stop, these couplings can slide completely onto a pipe and allow a connection to be made in tighter spaces. Unlike fittings with an integrated stop that have a minimum insertion depth, no-stop couplings have minimum and maximum allowable insertion depths. Both the minimum and the maximum insertion depths must be marked and a line connecting the two marks.

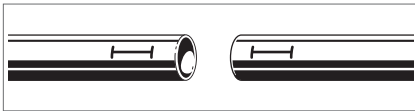

Pipe Diameter (in)	Minimum Insertion Depth (in)	Minimum Insertion Depth (mm)	Maximum Insertion Depth (in)	Maximum Insertion Depth (mm)
1/2	1 1/16	27	1 5/8	41
3/4	1 3/16	30	1 13/16	46
1	1 3/8	35	1 15/16	49
1 1/4	1 13/16	46	2 1/2	64
1 1/2	1 7/8	48	2 3/4	70
2	2	51	2 3/4	70
2 1/2	1 13/16	46	3 1/8	79
3	2 5/16	59	3 11/16	94
4	3 1/8	80	4 3/8	111

Table 12: Insertion depths for MegaPress no-stop couplings

Pipe Diameter (in)	Minimum Insertion Depth (in)	Minimum Insertion Depth (mm)	Maximum Insertion Depth (in)	Maximum Insertion Depth (mm)
1/2	1 1/16	27	2 3/4	70
3/4	1 3/16	30	2 13/16	71
1	1 3/8	35	3	76
1 1/4	1 13/16	46	3 1/2	89
1 1/2	1 7/8	48	3 9/16	90
2	2	51	3 11/16	94

Table 13: Insertion depths for MegaPress extended no-stop couplings

4.3 Space Requirements and Intervals



Not enough space

The connection may leak and/or ring/press gun may not fit around the fitting.

- Adhere to minimum space requirements.
- Make sure that the space required for pressing tools is available if fittings will be pressed immediately upstream or downstream from wall or ceiling penetrations.
- Take the minimum required distances into consideration during the planning phase of the project whenever possible.

4.3.1 Minimum Distance Between Fittings

To ensure a correct press, a minimum distance between press fittings must be maintained. Failure to provide this distance may result in an improper seal.

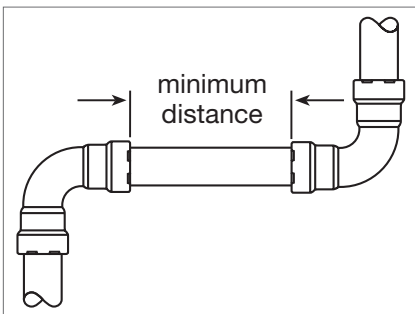

Pipe Diameter (in)	A minimum (in)	A minimum (mm)
1/2	1/4	7
3/4		
1		
1 1/4	1/2	13
1 1/2		
2		
2 1/2		
3		
4		

Table 14: Minimum distance between press fittings

4.3.2 Minimum Space Requirements

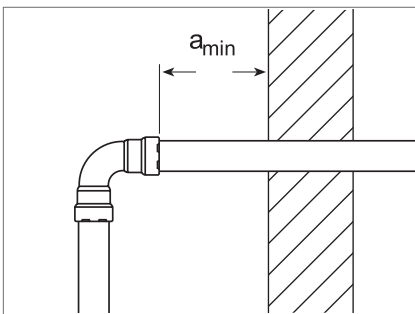

Ensure that the space required for Viega system pressing tools is available if press fittings will be executed immediately upstream and downstream from wall or ceiling penetrations.

Pipe Size (in)	Minimum space requirement, a_{min} for press tools (in)
	RIDGID RP241, RP320, RP330, RP340, and CT400 Press Tools Milwaukee M18 Press Tools
1/2 to 1	1 1/2
1 1/4 to 2	3/8
2 1/2 to 4	3/8

Table 15: MegaPress distance requirements for press jaws between pipes and walls

4.3.3 MegaPress Jaws Clearance Requirements

The minimum distance between pipe, or the pipe and the wall/ceiling construction, must be taken into consideration in the planning phase for a problem free work process. The following illustrate the clearance requirements for the jaws and fittings and the procedure for pressing fittings in tight quarters.



Pipe installed too closely together

Connection may leak

- Adhere to minimum intervals between fittings.
- Insert pipe to full insertion depth before pressing.

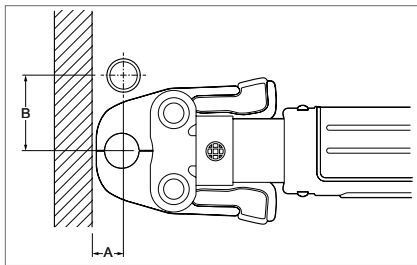

Pipe Diameter (in)	A minimum (in)	A minimum (mm)	B minimum (in)	B minimum (mm)
1/2	1	26	2 5/8	67
3/4	1 1/4	32	3 1/8	79
1	1 3/4	45	3 5/8	93

Table 16: MegaPress standard jaws clearance requirements

Pipe Diameter (in)	A minimum (in)	A minimum (mm)	B minimum (in)	B minimum (mm)
1/2	1 1/4	32	2 7/8	74
3/4	1 1/8	29	3	77

Table 17: MegaPress compact jaws clearance requirements

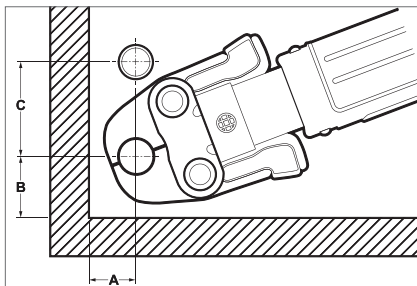

Pipe Diameter (in)	A minimum (in)	A minimum (mm)	B minimum (in)	B minimum (mm)	C minimum (in)	C minimum (mm)
1/2	1 1/4	32	1 7/8	48	3	77
3/4	1 1/2	39	2 1/8	54	3 1/2	89
1	2	51	2 1/2	64	4	102

Table 18: MegaPress standard jaws clearance requirements between pipe, wall, and floor

Pipe Diameter (in)	A minimum (in)	A minimum (mm)	B minimum (in)	B minimum (mm)	C minimum (in)	C minimum (mm)
1/2	1 1/2	39	2 1/8	54	3 1/8	80
3/4	1 3/8	35	2 1/8	54	3 3/8	86

Table 19: MegaPress compact jaws clearance requirements between pipe, wall, and floor

4.3.4 MegaPress Rings Clearance Requirements

Ensure that the space required for system pressing tools is available if Viega MegaPress fittings will be installed immediately upstream or downstream from ceiling penetrations.

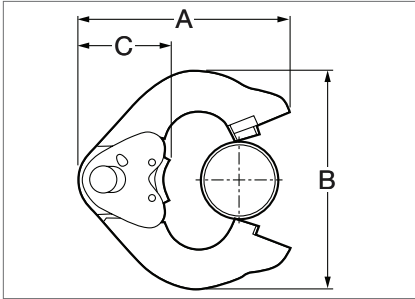

Pipe Diameter (in)	A minimum (in)	A minimum (mm)	B minimum (in)	B minimum (mm)	C minimum (in)	C minimum (mm)
1¼	6	153	6¼	159	2½	64
1½	6	153	6¾	172	2⅝	67
2	6	153	6⅞	175	2½	64
2½	6⅝	169	7⅝	194	2½	64
3	7½	191	8⅞	226	2½	64
4	8½	216	10⅝	264	2⅝	67

Table 20: MegaPress rings dimensions

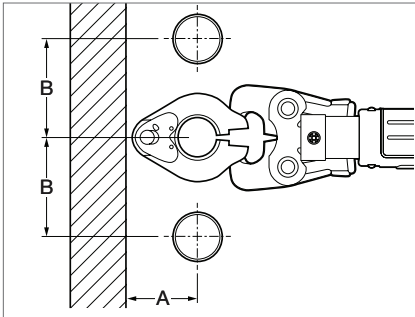

Pipe Diameter (in)	A minimum (in)	A minimum (mm)	B minimum (in)	B minimum (mm)
1¼	3¾	96	4⅞	124
1½	4	102	5⅞	131
2	4	102	5⅞	137
2½	4½	115	5⅞	150
3	4¾	121	6¾	172
4	5⅞	137	8¼	210

Table 21: MegaPress rings with V2/V3 actuator clearance requirements

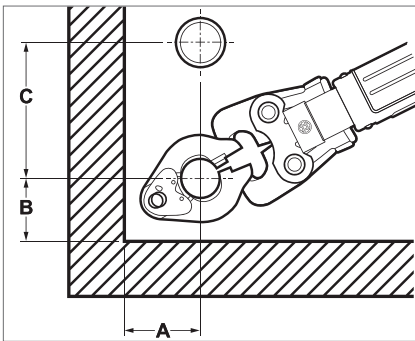

Pipe Diameter (in)	A minimum (in)	A minimum (mm)	B minimum (in)	B minimum (mm)	C minimum (in)	C minimum (mm)
1¼	3¾	96	3¾	96	4⅞	124
1½	4	102	4	102	5⅞	131
2	4	102	4	102	5⅞	137
2½	4½	115	4	102	5⅞	150
3	4¾	121	4¾	121	6¾	172
4	5⅞	137	5½	140	8¼	210

Table 22: MegaPress rings with V2/V3 actuator clearance requirements between pipe, wall, and floor

4.3.5 Pressing with Ring and Actuator in Tight Quarters

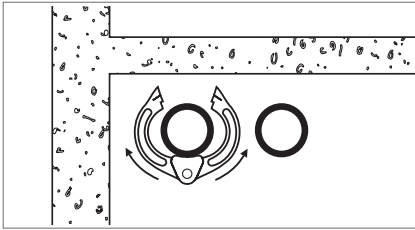

- Wrap the actuator ring around the press fitting with the opening facing away from you.

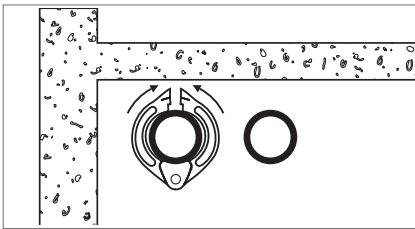

- Close the actuator ring tight around the fitting.

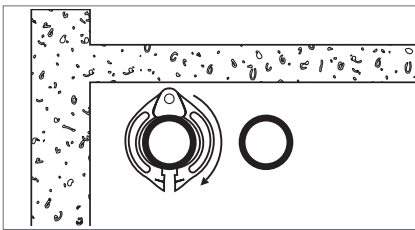

- Rotate the actuator ring until the press jaw receptacle is facing toward you.

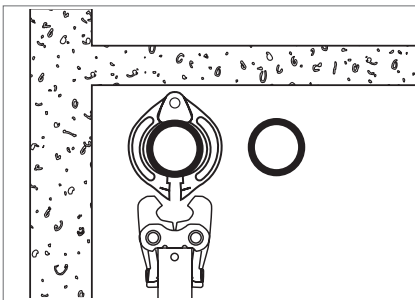

- Properly insert the press jaw and begin the press fitting procedure.

4.4 Welding

4.4.1 Welding Adjacent to a Fitting

To prevent damage to the sealing element, maintain proper welding distances from the fitting. If welding adjacent to the connection, weld a minimum of 4 inches away.

4.4.2 Welding In Line with a Fitting

To prevent damage to the sealing element, maintain proper welding distances from the fitting. If welding in line with the connection, weld a minimum of three feet away from the connection to protect the sealing element.

4.4.3 Welding Requirements

The installer should take precautions to keep the MegaPress connection cool:

- Wrap the connection with a cold wet rag.
- Protect the connection with a weld blanket.
- Prefabricate solder connections/welded fittings prior to installing the press fitting. (Ensure pipe has cooled before installing the press fitting.)
- Apply heat sink gel or spray or spot freezing.

4.5 Cutting the Pipe



Damaged pipe and/or sealing element

Press fittings can form improper connections as the result of damaged pipe and/or sealing elements.

- Do not use flame cutters when cutting the pipe.
- Do not use grease or oils when cutting the pipe.

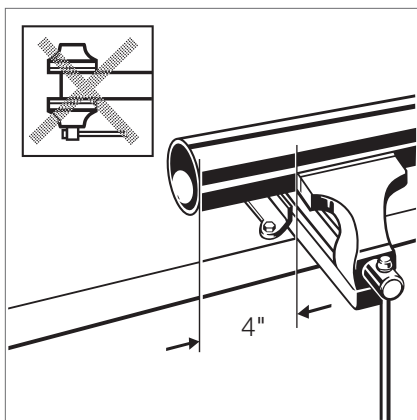

Note: Cut pipe a minimum of 4 inches away from the contact area of the vise to prevent possible damage to the pipe in the press area.



Avoid cutting through grooves, manufacturer's stamps, or engravings on the pipe's surface.

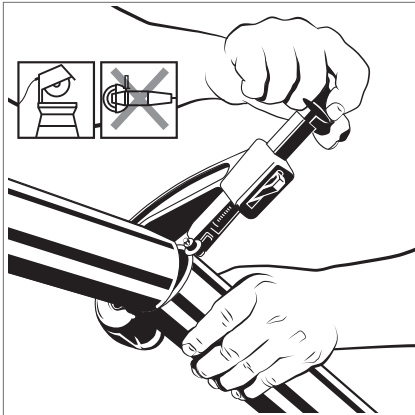

- Cut the pipe square using a displacement-type cutter or fine toothed saw.

4.6 Deburring the Pipe



Damage resulting from the wrong deburring tool

- Connections may leak if they are damaged by improper deburring.
- Failure to deburr piping will reduce the service life of the system and can cause premature leaks.

The pipe ends must be thoroughly deburred after cutting. Damage to or twisting of the sealing element during installation is prevented by deburring.

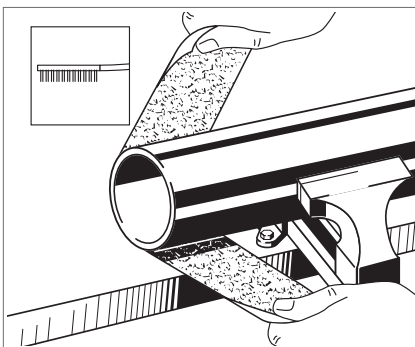

- Remove burr from inside and outside of piping and prep to proper insertion depth using a preparation tool or fine grit sandpaper.

4.7 Pressing the Fitting



WARNING!

Read and understand all instructions for installing Viega MegaPress fittings. Failure to follow all instructions may result in extensive property damage, serious injury, or death.

4.7.1 Viega MegaPress 1/2" to 2" Installation

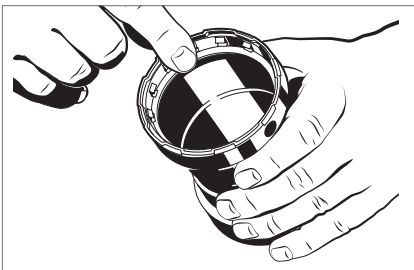

- Check the sealing element for correct fit:
 - The pipe end is not bent or damaged.
 - The pipe is deburred.
 - The correct sealing element is in the fitting.
 - The sealing element is undamaged.
 - The sealing element is completely in the bead.
- Check the separator ring for correct fit.
- Check the grip ring for correct fit.

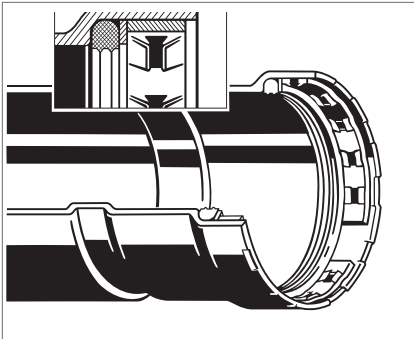
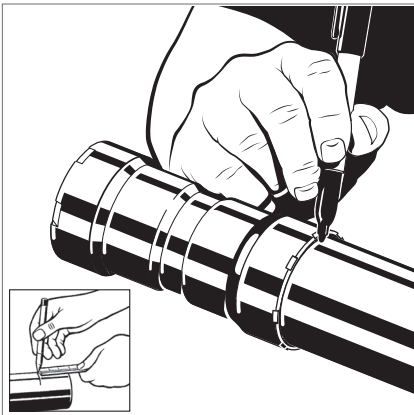

Illustration demonstrates proper fit of grip ring, separation ring, and sealing element.



- Measure insertion depth (see table below).
- Mark the proper insertion depth on the outside of the pipe. It is recommended that the depth marking be visible on the completed assembly.



Improper insertion depth

Improper insertion depth may result in an improper seal.

- Be sure to mark the correct insertion depth on the pipe before pressing the fitting. The depth marking shall be visible on the completed assembly.

Pipe Diameter (in)	Insertion Depth (in)	Insertion Depth (mm)
1/2	1 1/16	27
3/4	1 3/16	30
1	1 3/8	35
1 1/4	1 13/16	46
1 1/2	1 7/8	48
2	2	51

Table 23: Minimum insertion depths for MegaPress 1/2" to 2"

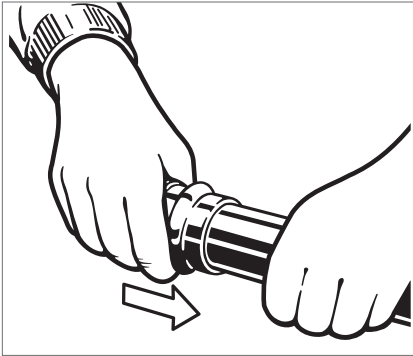

- While turning slightly, slide press fitting onto the pipe to the marked insertion depth.

Note: End of pipe must contact stop.

- Once the assembly is completed, it is recommended that the depth marking still be visible.

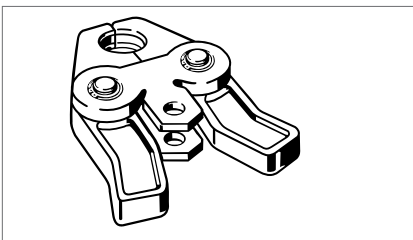

Viega MegaPress 1/2" to 1" fitting connections must be performed with MegaPress jaws. See Operator's Manual for proper tool instructions.

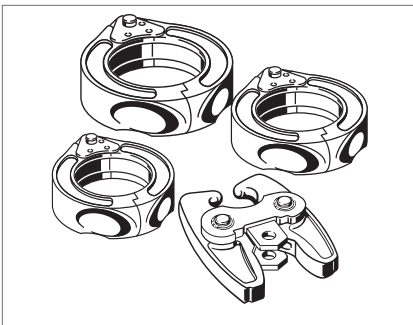

Viega MegaPress 1 1/4" to 2" fitting connections must be performed with MegaPress rings and V2 actuator. See Operator's Manual for proper tool instructions.



Use only MegaPress jaws and rings to press MegaPress fittings.

- See Operator's Manual for proper tool instructions.
- Use of incompatible jaws or rings will result in an improper connection. Do not use ProPress press jaws or rings.
- Do not mix actuators and rings from different manufacturers.

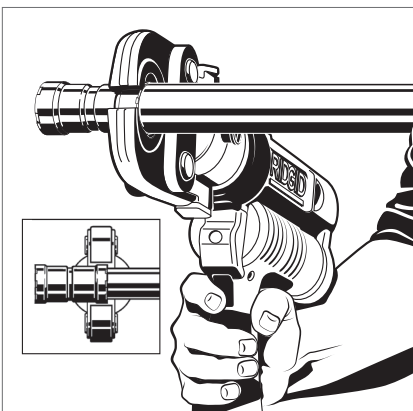

- For 1/2" to 1" fitting connections, open the MegaPress jaw and place at right angles on the fitting.
- Visually check insertion depth using mark on piping.



Do not press over pipe threads!

Install MegaPress fittings on plain end pipe only. Pressing fittings directly over threads will result in an improper seal.

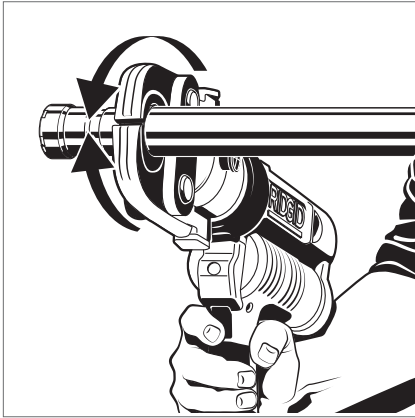

- Start the pressing process and hold the trigger until the jaw has engaged the fitting.



WARNING!

Keep extremities and foreign objects away from press tool during pressing operation to prevent injury or incomplete press.



DANGER!
High pressure

Pressure above the specified range or improper application and use could cause pipes to burst resulting in serious injury or even death.

- Fittings are for use with fuel gases and are intended for operating pressures 0 to 125 psi.

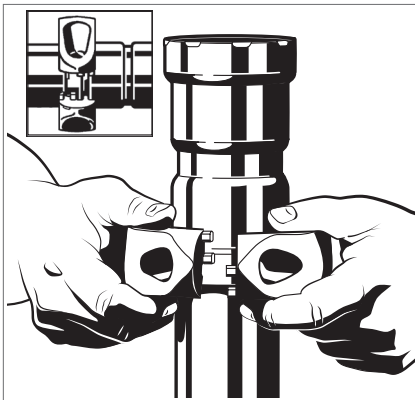

- For 1¼" to 2" fitting connections, open MegaPress ring and place at right angles on the fitting. MegaPress ring must be engaged on the fitting bead.
- Visually check insertion depth using mark on piping.

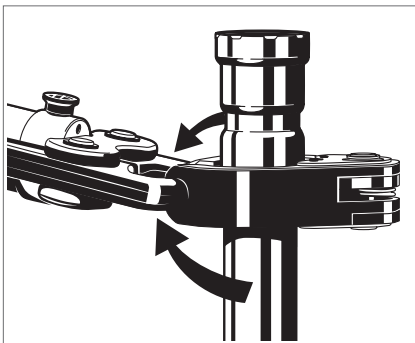

- Place V2 actuator onto MegaPress ring and start the pressing process.
- Hold the trigger until the actuator has engaged the MegaPress ring.



WARNING!

Keep extremities and foreign objects away from press tool during pressing operation to prevent injury or incomplete press.

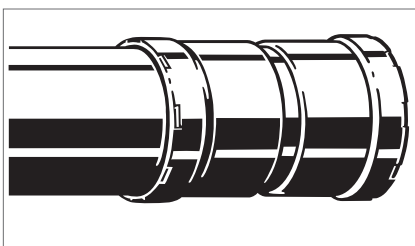

- Once the press is complete, remove MegaPress jaw from fitting or release V2 actuator from RIDGID MegaPress ring.
- Remove MegaPress ring from the fitting.
- Remove control label to indicate press has been completed.

4.7.2 Viega MegaPress 2½" to 4" Installation



WARNING!

Read and understand all instructions for installing Viega MegaPress 2½" to 4" fittings. Failure to follow all instructions may result in extensive property damage, serious injury, or death.

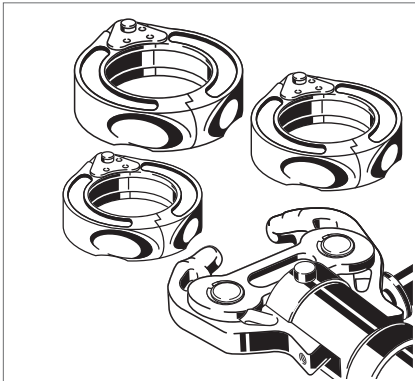

Use only rings that are compatible with MegaPress 2½" to 4" fittings.

- Viega MegaPress 2½" to 4" fitting connections must be made using MegaPress XL rings and a PressBooster or appropriate press tool with Z3 actuator.
- See Operator's Manual for proper tool instructions.
- Use of incompatible rings will result in an improper connection.
- Do not mix actuators and rings from different manufacturers.

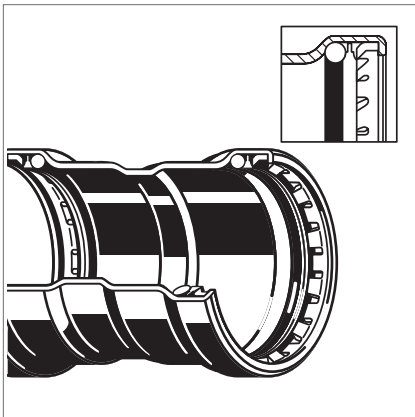

- Check the sealing element, separator ring, and grip ring for correct fit:
 - The pipe end is not bent or damaged.
 - The pipe is deburred.
 - The correct sealing element is in the fitting.
- Check the separator ring for correct fit.
- Check the grip ring for correct fit.

Illustration demonstrates proper fit of grip ring, separator ring, and sealing element.

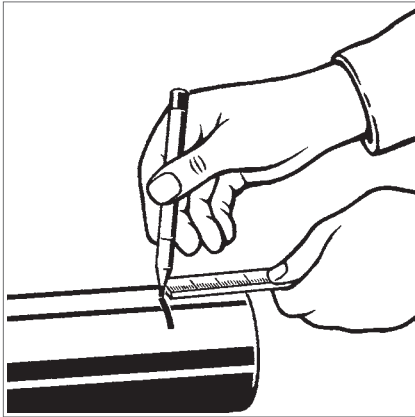

- Measure insertion depth (see table below).
- Mark the proper insertion depth on the outside of the pipe. It is recommended that the depth marking be visible on the completed assembly.



Improper insertion depth

Improper insertion depth may result in an improper seal.

- Be sure to mark the correct insertion depth on the pipe before pressing the fitting. The depth marking shall be visible on the completed assembly.

Pipe Diameter (in)	Insertion Depth (in)	Insertion Depth (mm)
2½	1 13/16	46
3	2 5/16	59
4	3 1/8	80

Table 24: Minimum insertion depths MegaPress 2½" to 4"

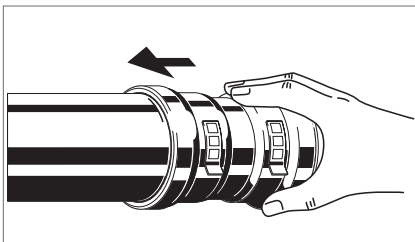

- While turning slightly, slide fitting onto the pipe to marked insertion depth.

Note: End of pipe must contact stop.

- Once the assembly is completed, it is recommended that the depth marking still be visible.

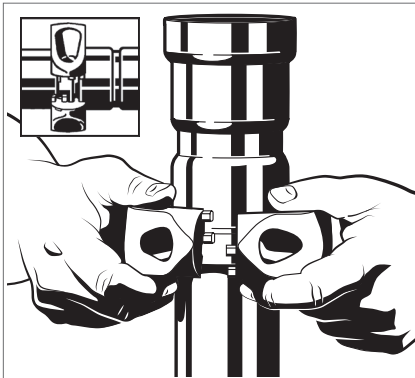

- Open the MegaPress ring and place at right angles on the fitting.
- MegaPress ring must be engaged on the fitting bead.
- Check insertion depth.



Do not press over pipe threads!

Install MegaPress fittings on plain end pipe only. Pressing fittings directly over threads will result in an improper seal.

To press MegaPress 2½" to 4" fittings, use either the MegaPress XL PressBooster or the MegaPress Z3 actuator. Use MegaPress XL (2½", 3", or 4") press ring with either tool.



WARNING!

Keep extremities and foreign objects away from press tool during pressing operation to prevent injury or incomplete press.

4.7.2.1 Using Viega MegaPress XL PressBooster

The PressBooster amplifies the mechanical force output. The PressBooster requires two presses of the press tool to execute a complete press for MegaPress 2½" to 4" fittings.

See the [MegaPress XL Press Booster Instructions for Use](#) for complete information on using the tool on the [Viega.us](#) website.

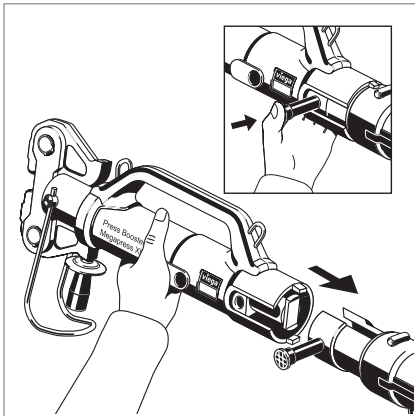

- Remove the retaining bolt of the press machine.
- Slide the PressBooster in via the press jaw fixture.
- Slide the retaining bolt of the press machine in as far as it will go.

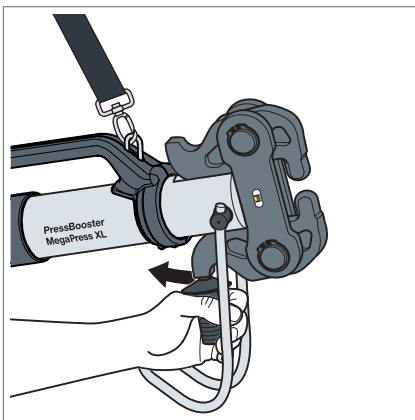

- Look at insertion depth mark on the pipe to make sure that the pipe is properly inserted into the fitting.
- To open the PressBooster jaw, pull the handle at the hinged adapter jaw back.

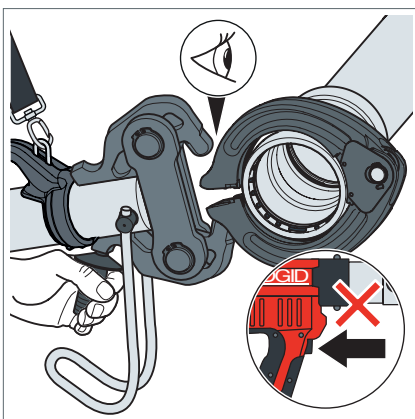

- Place PressBooster onto the MegaPress XL ring by inserting the ball heads of the hinged adapter jaw into the contact points of the press ring.



Before initiating a press make sure the ball heads sit correctly in the contact points of the press ring.

- Push the handle forward to close the hinged adapter jaw.

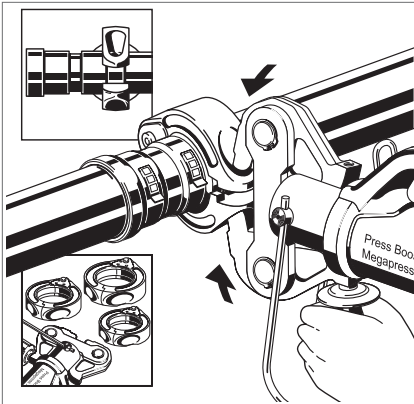

- Hold the trigger until the actuator has engaged the MegaPress ring.
- Wait two to three seconds and press the trigger a second time.

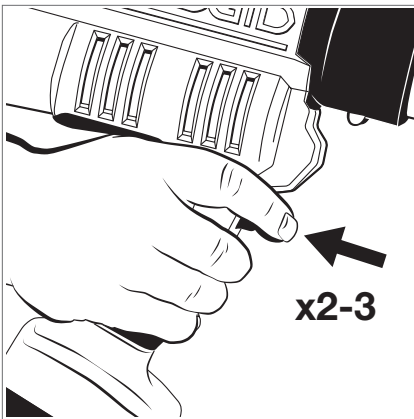

- The PressBooster requires two presses of the trigger to execute a complete press. A third press may be needed to initiate a release cycle to reset the rollers back to the original position.
- Once the pressing process is complete, the rollers at the front of the booster will retract and the hinged adapter jaw will open.
- Release the PressBooster from the MegaPress XL ring.
- Remove the MegaPress XL ring from the fitting.
- Remove control label to indicate press has been completed.

4.7.2.2 Using Viega MegaPress Z3 Actuator

The Z3 actuator amplifies the mechanical force output in order to execute a complete press for MegaPress 2½" to 4" fittings.

See the [MegaPress Z3 Actuator Instructions for Use](#) for complete information on using the tool on the Viega.us website.

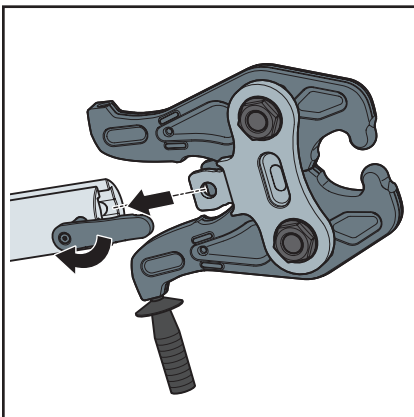

- On the press tool, rotate the retaining pin handle 180 degrees and pull it out to open the slot for the actuator.
- Insert the Viega Z3 actuator into the slot on the press tool.
- On the press tool, push the retaining pin back in and rotate it 180 degrees.



The handle of the actuator can be removed and attached to the opposite side of the actuator if necessary.

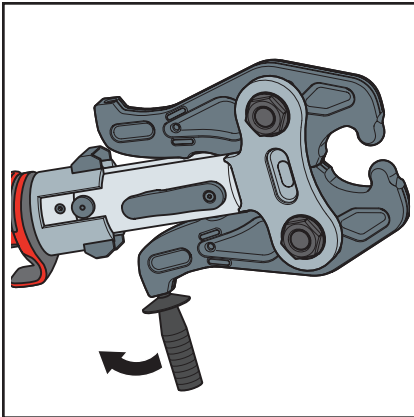

► Open the Viega Z3 actuator by pulling the handle back.

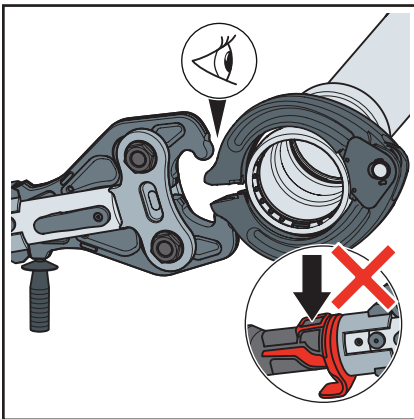

► Place the open Vieg Z3 actuator onto the press ring by inserting the ball heads of the actuator into the contact points of the press ring.



Before initiating a press make sure the ball heads sit correctly in the contact points of the press ring.

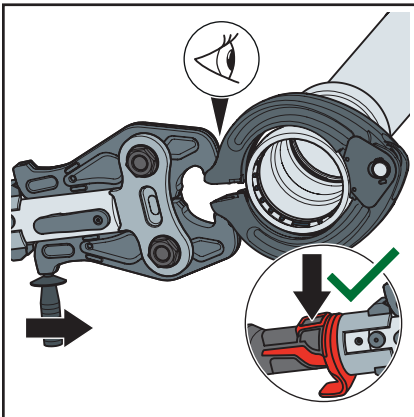

► Close the Z3 actuator.



WARNING!

Keep extremities and foreign objects away from press tool during pressing operation to prevent injury or incomplete press.

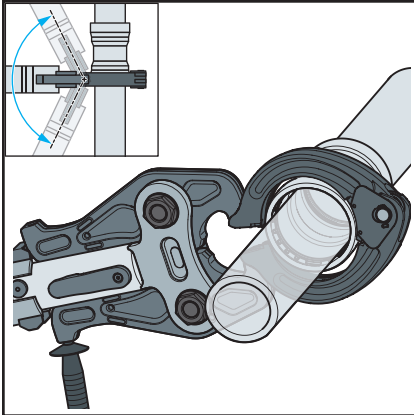

- Hold the press tool and handle of the Z3 actuator securely.
- Start the pressing process by holding the press tool trigger until the actuator has engaged the press ring.
- When the press cycle is complete, the actuator will stop and release.

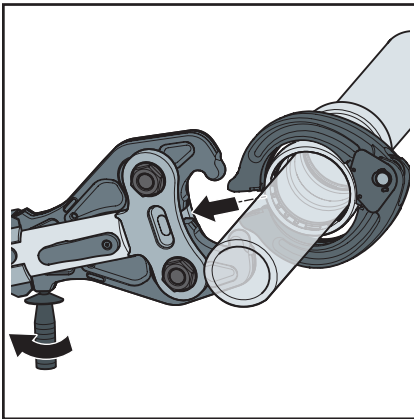

- Once the press is complete, open the Z3 actuator and take the actuator off the press ring.
- Remove the press ring from the fitting.

4.8 Pressure Testing

Viega Smart Connect technology provides a quick and easy way for installers to identify connections that need to be pressed. Unpressed connections are located by pressurizing the system with air or water.

Pressure test all installed pipe in accordance with local codes or, in the absence of local codes, in accordance with NFPA 54 or NFPA 58.



Smart Connect Testing

- Testing for unpressed connections using Smart Connect is not a replacement for pressure testing requirements of local codes and standards.
- If testing with compressed air, use an approved leak-detect solution.

Water testing with Viega Smart Connect:

- Use a range of 15 to 85 psi.
- If an unpressed fitting is found, make sure the pipe is fully inserted before completing the press.
- If the initial test is successful, system may be pressure tested as required up to 600 psi.

Testing with air can be dangerous at high pressures. When air testing with Viega Smart Connect:

- Use a range of ½ psi to 45 psi.
- If an unpressed fitting is found, make sure the pipe is fully inserted before completing the press.
- If the initial test is successful, system may be pressure tested as required up to 200 psi.

Viega recommends air testing of gas systems at a minimum of ½ psi.



The installation, inspection, testing, and purging of the fuel gas system shall be in accordance with local codes or, in the absence of local codes, tested in accordance with the International Fuel Gas Code, NFPA 54/National Fuel Gas Code z223.1, the Uniform Plumbing Code, NFPA 58 or CSA B 149.1 as applicable.

4.9 Disposal

Separate the product and packaging materials (e.g. paper, metal, plastic, non-ferrous metals) and dispose in accordance with all national, state, and regional requirements.

5 Limited Warranty

5.1 Limited Warranty for Viega MegaPress

Subject to the conditions and limitations in this Limited Warranty, Viega LLC (Viega) warrants to end users, installers, and distribution houses that its Viega MegaPress metal press fittings including MegaPress, MegaPress FKM, MegaPress 304 FKM, MegaPress 316, and MegaPress 316 FKM (Viega Product) with application appropriate sealing element when properly installed in non-industrial and non-marine applications and under specified operating conditions of use shall be free from failure caused by manufacturing defects for a period of fifteen (15) years from date of installation. MegaPress valves, when properly installed and under normal conditions of use, will be free of failure from manufacturing defects for a period of five (5) years from date of installation.

Under this Limited Warranty, you only have a right to a remedy if the failure or leak resulted from a manufacturing defect in the Viega Product and the failure or leak occurs during the warranty period. You do not have a remedy under this warranty and the warranty remedy does not apply if the failure or any resulting damage is caused by (1) components other than those manufactured or sold by Viega, such as black iron pipe; (2) not designing, installing, inspecting, testing, or maintaining the Viega Product in accordance with Viega's installation and product instructions in effect at the time of installation, and other specifications and approvals applicable to the installation; (3) use of Viega Product under non recommended system operating conditions, improper handling, and protection of the Viega Product prior to, during, and after installation, inadequate freeze protection, or exposure to environmental conditions not recommended for the application; or (4) acts of nature, such as, but not limited to, earthquakes, fire, or weather damage.

In the event of a leak or other failure of the Viega Product covered by this warranty, it is the responsibility of the end user to take appropriate measures to mitigate any damage, to include making timely repairs. Only if the warranty applies will Viega be responsible for the remedy under this warranty. The part or parts which you claim failed should be kept and Viega contacted by writing to the address below or telephoning 1-800-976-9819 within thirty (30) calendar days after the leak or other failure and identifying yourself as having a warranty claim. You should be prepared to ship, at your expense, the product which you claim failed due to a manufacturing defect, and document the date of installation and the amount of the repair or replacement if performed by you. Within a reasonable time after receiving the product, Viega will investigate the reasons for the failure, which includes the right to inspect the product at a Viega location and reasonable access to the site of damage. Viega will notify you in writing as to the results of its review.

In the event that Viega determines that the failure or leak was the result of a manufacturing defect in the Viega Product covered by this warranty and this warranty applies, the EXCLUSIVE AND ONLY REMEDY under this

warranty shall be the reimbursement for reasonable charges for repair or replacement of the Viega Product itself. VIEGA SHALL NOT BE LIABLE FOR ANY CONSEQUENTIAL OR OTHER DAMAGE (FOR EXAMPLE, ECONOMIC LOSS, WATER OR PROPERTY OR MOLD REMEDIATION) UNDER ANY LEGAL THEORY AND WHETHER ASSERTED BY DIRECT ACTION, FOR CONTRIBUTION OR INDEMNITY OR OTHERWISE.

THE ABOVE WARRANTY IS IN LIEU OF ALL OTHER WARRANTIES, EXPRESS OR IMPLIED, INCLUDING, BUT NOT LIMITED TO, THE IMPLIED WARRANTIES OF MERCHANTABILITY AND FITNESS FOR A PARTICULAR PURPOSE OR ANY STATUTE OF LIMITATIONS RELATING TO SUCH WARRANTIES. Other than this Limited Warranty, Viega does not authorize any person or firm to create for it any other obligation or liability in connection with its products.

This Limited Warranty gives you specific legal rights and you also may have other rights which may vary from state to state. This warranty shall be interpreted and applied under the law of the state in which the product is installed and is intended as a COMMERCIAL WARRANTY.

5.2 Limited Warranty for Viega MegaPressG

Subject to the conditions and limitations in this Limited Warranty, Viega LLC (Viega) warrants to end users, installers, and distribution houses that its Viega MegaPressG metal press fittings (Viega Product) with application appropriate sealing element when properly installed in non-industrial and non-marine applications and Viega MegaPressG Approved Applications for natural and fuel gases and lubricant, and approved fuels, lubricants, and oils, under Viega specified system operating conditions, shall be free from failure caused by manufacturing defects for a period of fifteen (15) years from date of installation. MegaPressG Valves, when properly installed and under normal conditions of use, will be free of failure from manufacturing defects for a period of five (5) years from date of installation.

Under this Limited Warranty, you only have a right to a remedy if the failure or leak resulted from a manufacturing defect in the Viega Product and the failure or leak occurs during the warranty period. You do not have a remedy under this warranty and the warranty remedy does not apply if the failure or any resulting damage is caused by (1) components other than those manufactured or sold by Viega, such as black iron pipe; (2) not designing, installing, inspecting, testing, or maintaining the Viega Product in accordance with Viega's installation and product instructions in effect at the time of installation, and other specifications and approvals applicable to the installation; (3) use of Viega Product under non recommended system operating conditions, improper handling, and protection of the Viega Product prior to, during, and after installation, inadequate freeze protection, or exposure to environmental conditions not recommended for the application; or (4) acts of nature, such as, but not limited to, earthquakes, fire, or weather damage.

In the event of a leak or other failure of the Viega Product covered by this warranty, it is the responsibility of the end user to take appropriate measures

to mitigate any damage, to include making timely repairs. Only if the warranty applies will Viega be responsible for the remedy under this warranty. The part or parts which you claim failed should be kept and Viega contacted by writing to the address below or telephoning 1-800-976-9819 within thirty (30) calendar days after the leak or other failure and identifying yourself as having a warranty claim. You should be prepared to ship, at your expense, the product which you claim failed due to a manufacturing defect, and document the date of installation and the amount of the repair or replacement if performed by you. Within a reasonable time after receiving the product, Viega will investigate the reasons for the failure, which includes the right to inspect the product at a Viega location and reasonable access to the site of damage. Viega will notify you in writing as to the results of its review.

In the event that Viega determines that the failure or leak was the result of a manufacturing defect in the Viega Product covered by this warranty and this warranty applies, the EXCLUSIVE AND ONLY REMEDY under this warranty shall be the reimbursement for reasonable charges for repair or replacement of the Viega Product itself. VIEGA SHALL NOT BE LIABLE FOR ANY CONSEQUENTIAL OR OTHER DAMAGE (FOR EXAMPLE, ECONOMIC LOSS, WATER OR PROPERTY OR MOLD REMEDIATION) UNDER ANY LEGAL THEORY AND WHETHER ASSERTED BY DIRECT ACTION, FOR CONTRIBUTION OR INDEMNITY OR OTHERWISE.

THE ABOVE WARRANTY IS IN LIEU OF ALL OTHER WARRANTIES, EXPRESS OR IMPLIED, INCLUDING, BUT NOT LIMITED TO, THE IMPLIED WARRANTIES OF MERCHANTABILITY AND FITNESS FOR A PARTICULAR PURPOSE OR ANY STATUTE OF LIMITATIONS RELATING TO SUCH WARRANTIES. Other than this Limited Warranty, Viega does not authorize any person or firm to create for it any other obligation or liability in connection with its products.

This Limited Warranty gives you specific legal rights and you also may have other rights which may vary from state to state. This warranty shall be interpreted and applied under the law of the state in which the product is installed and is intended as a COMMERCIAL WARRANTY.

5.3 Limited Warranty for Viega Metal Systems for Industrial Applications

Industrial applications are defined as non-residential and non-commercial applications not normally accessible to the general public, including manufacturing, mining, process or fabrication environments.

Subject to the terms and conditions of this Limited Warranty, Viega LLC (Viega) warrants to end users, installers and distribution houses that its Viega metal press products (Viega product) when properly installed in industrial applications shall be free from failure caused by manufacturing defects for a period of two (2) years from date of installation.

Under this Limited Warranty, you only have a right to a remedy if the failure or leak resulted from a manufacturing defect in the Viega product and the failure or leak occurs during the warranty period. You do not have

a remedy under this warranty and the warranty remedy does not apply if the failure or any resulting damage is caused by (1) components other than those sold by Viega; (2) not designing, installing, inspecting, testing, or maintaining the Viega product in accordance with Viega's installation and product instructions in effect at the time of installation and other specifications and approvals applicable to the installation; (3) improper handling and protection of the Viega product prior to, during and after installation, inadequate freeze protection, or exposure to environmental or operating conditions not recommended for the application; or (4) acts of nature, such as, but not limited to earthquakes, fire, or weather damage. Final approval as to use compatibility to a specific process or fluid application is the responsibility of the engineer of record or responsible design/facilities personnel and this Limited Warranty only applies to manufacturing defects in the Viega Product.

In the event of a leak or other failure in the Viega product covered by this warranty, it is the responsibility of the end user to take appropriate measures to diminish any damage, to include making timely repairs. Only if the warranty applies will Viega be responsible for the remedy under this warranty. The part or parts which you claim failed should be kept and Viega contacted by writing to the address below or telephoning 1-800-976-9819 within thirty (30) calendar days after the leak or other failure and identifying yourself as having a warranty claim. You should be prepared to ship, at your expense, the product which you claim failed due to a manufacturing defect, document the date of installation, and the amount of the repair or replacement if performed by you. Within a reasonable time after receiving the product, Viega will investigate the reasons for the failure, which includes the right to inspect the product at a Viega location and reasonable access to the site of damage. Viega will notify you in writing as to the results of its review.

In the event that Viega determines that the failure or leak was the result of a manufacturing defect in the Viega Product covered by this warranty and to which this warranty applies, the EXCLUSIVE AND ONLY REMEDY under this warranty shall be the reimbursement for reasonable charges for repair or replacement of the Viega Product itself. VIEGA SHALL NOT BE LIABLE FOR CONSEQUENTIAL OR OTHER DAMAGE (FOR EXAMPLE, ECONOMIC LOSS, WATER OR PROPERTY OR MOLD REMEDIATION) UNDER ANY LEGAL THEORY AND WHETHER ASSERTED BY DIRECT ACTION, FOR CONTRIBUTION OR INDEMNITY OR OTHERWISE.

THE ABOVE WARRANTY IS IN LIEU OF ALL OTHER WARRANTIES, EXPRESS OR IMPLIED, INCLUDING, BUT NOT LIMITED TO, THE IMPLIED WARRANTIES OR ANY STATUTE OF LIMITATIONS RELATING TO SUCH WARRANTIES. Other than this Limited Warranty, Viega does not authorize any person or firm to create for it any other obligation or liability in connection with its products.

This Limited Warranty gives you specific legal rights and you also may have other rights which may vary from state to state. This warranty shall be interpreted and applied under the law of the state in which the product is installed and is intended as a Commercial Warranty.

> Viega LLC
585 Interlocken Blvd.
Broomfield, CO 80021

Phone (800) 976-9819
www.viega.us

IM-MP 724992 0324 MegaPress (EN)

©2024, Viega®, ManaBloc®, MegaPress®, ProPress®, SeaPress®, Smart Connect®, Climate Mat®, Climate Panel®, Climate Trak®, PureFlow®, XL®, Viega Eco Plus®, and Viega: Connected in quality® are trademarks of Viega Holding GmbH & Co. KG. Eco Brass® is a registered trademark of Mitsubishi Shindoh Co., LTD. RIDGID® is a registered trademark of RIDGID, Inc. LoopCAD® is a registered trademark of Avenir Software Inc. LEED® is a registered trademark of the U.S. Green Building Council®.

