

Connected in quality.

VIEGA MEGAPRESS® STAINLESS SYSTEMS

POCKET GUIDE



viega.us

viega

Viega.

Connected in quality.

Building on Tradition

Founded 125 years ago, Viega is a privately owned international group of companies. In the United States, Canada, Mexico, and Latin America, Viega specializes in plumbing, heating, and pipe-joining technologies. The values of Viega's founder, Franz-Anselm Viegner, are just as present today as they were when he started the company in 1899. Courage, passion, and innovative spirit are still the basics of Viega's foundation.

At Viega, Safety Is Priority.

Safe, certain, and secure, Viega fittings are designed for peace of mind.

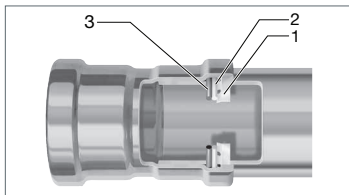

1. In MegaPress stainless fittings, the 420 stainless steel grip ring's teeth cut into the pipe and lock the fitting securely in place.

2. For ½" to 2" fittings, a 304 stainless steel separator ring protects the sealing element from damage by creating a positive physical separation during installation. For 2½" to 4" fittings, a PBT (Polybutylene Terephthalate) separator ring protects the sealing element.
3. The FKM sealing element in MegaPress 304/316 FKM fittings and the EPDM sealing element in MegaPress 316 fittings ensure watertight or airtight connections.

In all MegaPress stainless fittings, Viega's unique Smart Connect technology helps installers ensure that they have pressed all connections.



DANGER!

Read and understand all instructions for installing Viega MegaPress stainless fittings. Failure to follow all instructions may result in extensive property damage, serious injury, or death.



A white dot on Viega MegaPress 304 FKM and 316 FKM fittings indicates Smart Connect® technology with an FKM sealing element. A green dot on a Viega MegaPress 316 fitting indicates Smart Connect technology with an EPDM sealing element. For a current list of applications, please see the [Applications Chart](#).

Introduction	4
MegaPress Stainless Systems	4
System Data	6
Viega MegaPress 304 FKM Fitting Systems	6
Viega MegaPress 316 Fitting Systems	7
Viega MegaPress 316 FKM Fitting Systems	8
Tech Data	9
Viega MegaPress 304 FKM Ball Valve, Models 4170 and 4170XL	9
Viega MegaPress 304 FKM 3-Piece Ball Valve, Models 4175.8, 4175.8XL	10
Viega MegaPress 316 Ball Valve, Models 5170 and 5170XL	11
Viega MegaPress 316 3-Piece Ball Valve, Models 5175.8, 5175.8XL	12
Viega MegaPress 316 Check Valve, Model 5174	13
Product Instructions	15
Viega MegaPress Stainless ½" to 2" Fittings	15
Viega MegaPress Stainless 2½" to 4" Fittings	16
Technical Information	18
Approved Applications	18
Sealing Element Description	20
Viega MegaPress Stainless Steel Pipe Marking Guide	21
No-Stop Couplings	22
Welding	22
Minimum Distance Between MegaPress Connections	22
General Installation Notes	23
Deflection	24
Tool Clearances	25
Pressing with Ring and Actuator in Tight Quarters	27
Dimensional Documentation	29
MegaPress Stainless	29
Frequently Asked Questions	41
Limited Warranty	42
Viega Metal Systems for Industrial Applications	42
Viega Marine Applications	43



This document is subject to updates. For the most current Viega technical literature, please visit www.viega.us.



Viega products are designed to be installed by licensed and trained plumbing and mechanical professionals who are familiar with Viega products and their installation. **Installation by non-professionals may void Viega LLC's warranty.**

MegaPress Stainless Systems

Viega MegaPress stainless systems can help reduce installation time by up to 90 percent compared to traditional methods of pipe joining. Soldering and welding can be messy and time consuming, and connections are not always reliable. With Viega press technology, installers can make consistent, secure press connections in a matter of seconds, without flame or heavy equipment.

The fittings require no soldering or welding and are installed with electrohydraulic press tools (battery-powered or corded press tools).

Viega MegaPress stainless fittings can be customized for a wide variety of applications in industrial, commercial, or residential projects.

Fire Protection You Can Count On

With FM and UL certification for MegaPress ½" to 2" sizes, with 2½" to 4" sizes soon to be added to the listing, Viega is introducing the latest press system for the fire protection market. Viega MegaPress 304 FKM and 316 fittings can be used in prefabricated assemblies, producing a straight, clean installation.

Backed by a written limited warranty and approved for NFPA 13, 13D, and 13R fire sprinkler systems, MegaPress stainless can be installed in industrial applications or commercial projects like hotels and dorms. With Viega's cold-press technology, installations in attics and tight corners are safer than with traditional joining methods. Installers don't need to carry heavy equipment or bother with metal shavings or cutting oils.



It is the responsibility of the installer or any other parties to adhere to all applicable local rules and regulations governing the nature of the installation.



The use of the system for applications other than those listed or outside of these parameters must be approved by Viega Technical Support (techsupport@viega.us).

Smart Connect Technology – Security Under Pressure

Locating unpressed connections is an important step in the pressure-testing process. Viega MegaPress stainless includes Smart Connect technology, providing quick and easy identification of unpressed connections during a pressure test.

Smart Connect technology is an integral part of the design of the fitting, providing a path for liquids and/or gases from inside the system past the sealing element of an unpressed connection. When pressed according to our Product Instructions, the fluid path is altered, creating a reliable, leakproof connection.

Unpressed connections are located by pressurizing the system with air or water. When testing with water, the proper pressure range is 15 to 85 psi. Pressure testing with air can be dangerous at high pressures. When testing with compressed air, the proper pressure range is 1/2 to 45 psi. Following a successful Smart Connect test, the system may be pressure tested up to 600 psi maximum for water and 200 psi maximum for air if required by local code requirements.

i Testing for unpressed connections using Smart Connect is not a replacement for pressure-testing requirements of local codes and standards.



1 Identify an unpressed connection during pressure testing when water flows past the sealing element.

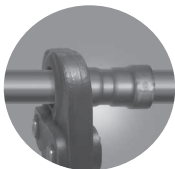

2 Upon identification, use the press tool to press the fitting, making a secure, leakproof connection.

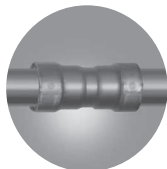

3 Viega MegaPress stainless connections are fast, flameless, and reliable.

Viega MegaPress 304 FKM Fitting Systems



MegaPress 304 FKM fittings are designed to be used with standard IPS ASTM A312 stainless steel-pipe to form a complete press system that is

ideal for industrial applications. MegaPress 304 FKM ½" to 2" fittings can be used with Schedule 5 to Schedule 40 stainless steel-pipe and 2½" to 4" fittings can be used with Schedule 10 to Schedule 40 stainless steel-pipe. A MegaPress 304 FKM system can stand up to harsh environments while transporting process water, diesel fuel, lube oil, ammonia, low-pressure steam, or any number of other essential fluids or gases. MegaPress 304 FKM fittings in sizes from ½" to 4" are offered in configurations that include elbows, couplings, reducers, tees, reducing tees, threaded adapters, unions, caps, and flanges.

Components

- Alloy: 304 stainless steel
- FKM sealing element
- 420 stainless steel grip ring
- 304 stainless steel separator ring for ½" to 2" fittings
- PBT separator ring for 2½" to 4" fittings

Operating Parameters

- Operating Pressure: 200 psi max
- Operating Temperatures: 14°F to 284°F (with temperature spikes up to 356°F)

Listings and Certificates

- ABS type approval
- BV (Bureau Veritas)
- CRN 23076.5 A/B/C
- DNV-GL
- IAPMO/ANSI/CAN Z1117
- ICC-ES LC1002
- Lloyd's Register
- NFPA 13, 13D, 13R
- FM Class 1920 (½" to 2" only)
- ANSI/CAN/UL 213 (½" to 3" only)

Compliant With

- ASME B31, B31.1, B31.3, B31.9
- ASTM A312
- ASTM A554
- IAPMO Uniform Mechanical Code (UMC)
- ICC International Mechanical Code (IMC)
- ICC International Residential Code (IRC)
- National Building Code of Canada (NBCC)
- National Plumbing Code of Canada (NPCC)

Approved Applications

- Low-pressure steam
- Industrial gases
- Compressed air
- Lube oil
- Caustic solutions
- Acid solutions
- Vacuum
- Process water (non-potable)

For more specific information on applications for MegaPress 304 FKM, contact Viega Technical Services at 1-800-976-9819.

MegaPress 304 FKM systems are approved for underground use. When installed underground, MegaPress 304 FKM should have proper corrosion protection in accordance with local and national codes.

Recommended Tools

- Standard-size press tool (minimum hydraulic ram output of 7,200 lbs.)
- #56013 MegaPress jaw/ring kit (½" to 2")
- #26200 MegaPress XL PressBooster with 2½" press ring
- #57078 MegaPress XL 3" and 4" press ring kit
- #57081 Z3 Actuator with 2½" press ring (must be used with press gun with minimum 80mm press stroke)

Smart Connect® Technology

MegaPress 304 FKM fittings are manufactured with Viega's unique Smart Connect technology. A design of the fitting, Smart Connect technology allows identification of an unpressed fitting during pressure testing.

Viega MegaPress 316 Fitting Systems



MegaPress 316 fittings are designed to be used with standard IPS ASTM A312 stainless steel-pipe and are ideal for industrial

applications. MegaPress 316 ½" to 2" fittings can be used with Schedule 5 to Schedule 40 stainless steel-pipe and 2½" to 4" fittings can be used with Schedule 10 to Schedule 40 stainless-steel pipe. A MegaPress 316 system can stand up to harsh environments while transporting process water, potable water, ammonia, low-pressure steam or any number of other essential fluids or gases. MegaPress 316 fittings in sizes from ½" to 4" are offered in configurations that include elbows, couplings, reducers, tees, reducing tees, threaded adapters, unions, caps and flanges.

Components

- Alloy: 316 stainless steel
- EPDM sealing element
- 420 stainless steel grip ring
- 304 stainless steel separator ring for ½" to 2" fittings
- PBT separator ring for 2½" to 4" fittings

Operating Parameters

- Operating Pressure: 200 psi max
- Operating Temperatures: 0° to 250°F

Listings and Certificates

- ABS type approval
- BV (Bureau Veritas)
- CRN 23076.5 A/B/C
- DNV-GL
- IAPMO/ANSI/CAN Z1117
- ICC-ES LC1002
- Lloyd's Register
- NFPA 13, 13D, 13R
- NSF/ANSI 61
- NSF/ANSI 372
- FM Class 1920 (½" to 2" only)
- ANSI/CAN/UL 213 (½" to 3" only)

Compliant With

- ASME B31, B31.1, B31.3, B31.9
- ASTM A312
- ASTM A554
- IAPMO California Plumbing Code (CPC)
- IAPMO National Standard Plumbing Code (NSPB)
- IAPMO Uniform Mechanical Code (UMC)
- IAPMO Uniform Plumbing Code (UPC)
- ICC International Mechanical Code (IMC)
- ICC International Plumbing Code (IPC)
- ICC International Residential Code (IRC)
- National Building Code of Canada (NBCC)
- National Plumbing Code of Canada (NPCC)

Approved Applications

- Low-pressure steam
- Industrial gases
- Potable water
- Process water (non-potable)
- Caustic solutions
- Acid solutions
- Vacuum

For more specific information on applications for MegaPress 316, contact Viega Technical Services at 1-800-976-9819.

MegaPress 316 systems are approved for underground use. When installed underground, MegaPress 316 should have proper corrosion protection in accordance with local and national codes.

Recommended Tools

- Standard-size press tool (minimum hydraulic ram output of 7,200 lbs.)
- #56013 MegaPress jaw/ring kit (½" to 2")
- #26200 MegaPress XL PressBooster with 2½" press ring
- #57078 MegaPress XL 3" and 4" press ring kit
- #57081 Z3 Actuator with 2½" press ring (must be used with press gun with minimum 80mm press stroke)

Smart Connect® Technology

MegaPress 316 fittings are manufactured with Viega's unique Smart Connect technology. A design of the fitting, Smart Connect technology allows identification of an unpressed fitting during pressure testing.

Viega MegaPress 316 FKM Fitting Systems



MegaPress 316 FKM fittings are designed to be used with standard IPS ASTM A312 stainless steel-pipe to form a complete press system that is

ideal for industrial applications. MegaPress 316 FKM ½" to 2" fittings can be used with Schedule 5 to Schedule 40 stainless steel-pipe, and 2½" to 4" fittings can be used with Schedule 10 to Schedule 40 stainless steel-pipe. A MegaPress 316 FKM system can stand up to harsh environments while transporting process water, diesel fuel, lube oil, low-pressure steam, or any number of other essential fluids or gases.

MegaPress 316 FKM fittings in sizes from ½" to 4" are offered in configurations that include elbows, couplings, reducers, tees, reducing tees, threaded adapters, unions, caps, and flanges.

Components

- Alloy: 316 stainless steel
- FKM sealing element
- 420 stainless steel grip ring
- 304 stainless steel separator ring for ½" to 2" fittings
- PBT separator ring for 2½" to 4" fittings

Operating Parameters

- Operating Pressure: 200 psi max
- Operating Temperatures: 14°F to 284°F (with temperature spikes up to 356°F)

Listings and Certificates

- ABS type approval
- CRN 23076.5 A/B/C
- IAPMO/ANSI/CAN Z1117
- ICC-ES LC1002
- Lloyd's Register

Compliant With

- ASME B31, B31.1, B31.3, B31.9
- ASTM A312
- ASTM A554
- IAPMO Uniform Mechanical Code (UMC)
- ICC International Mechanical Code (IMC)
- ICC International Residential Code (IRC)
- National Building Code of Canada (NBCC)
- National Plumbing Code of Canada (NPCC)

Approved Applications

- Process water (non-potable)
- Low-pressure steam
- Industrial gases
- Compressed air
- Lube oil
- Caustic solutions
- Acid solutions
- Vacuum

For more specific information on applications for MegaPress 316 FKM, contact Viega Technical Services at 1-800-976-9819.

MegaPress 316 FKM systems are approved for underground use. When installed underground, MegaPress 316 FKM should have proper corrosion protection in accordance with local and national codes.

Recommended Tools

- Standard-size press tool (minimum hydraulic ram output of 7,200 lbs.)
- #56013 MegaPress jaw/ring kit (½" to 2")
- #26200 MegaPress XL PressBooster with 2½" press ring
- #57078 MegaPress XL 3" and 4" press ring kit
- #57081 Z3 Actuator with 2½" press ring (must be used with press gun with minimum 80mm press stroke)

Smart Connect® Technology

MegaPress 316 FKM fittings are manufactured with Viega's unique Smart Connect technology. A design of the fitting, Smart Connect technology allows identification of an unpressed fitting during pressure testing.

Viega MegaPress 304 FKM Ball Valve, Models 4170 and 4170XL

The MegaPress 304 FKM stainless steel ball valve is equipped with a full port, 304 stainless steel 2-piece body and stainless steel press ends. The ball valve features an FKM sealing element, a 420 stainless grip ring, a 304 stainless separator ring, FKM stem seals, a locking stainless steel handle, and Viega's Smart Connect technology for easy identification of unpressed connections during pressure testing.

Features

- 304 stainless steel ball
- Body material designation: CF8 1.4301
- Blowout-proof 316 stainless steel stem
- 304 stainless steel locking handle
- Reinforced PTFE seats
- Smart Connect technology
- ISO 5211 mounting pad (for 2½", 3", and 4" only)

Ratings

- Operating Temperatures: 14°F to 284°F (with temperature spikes up to 356°F)
- Max. Operating Pressure ½" to 2": 250 CWP
- Max. Operating Pressure 2½" to 4": 200 CWP

Valve Size (in)	Valve Stem Nut Size	Stem Nut		Cv (US gal/min)
		ft/lbs	(Nm)	
½	M8	3.7 to 7.5	5 to 10	15.5
¾	M8	3.7 to 7.5	5 to 10	33.4
1	M8	3.7 to 7.5	5 to 10	46.4
1¼	M8	3.7 to 7.5	5 to 10	93.5
1½	M8	3.7 to 7.5	5 to 10	124
2	M8	3.7 to 7.5	5 to 10	246
2½	M8	22.1 to 44.3	30 to 60	403
3	M8	22.1 to 44.3	30 to 60	606
4	M8	22.1 to 44.3	30 to 60	1,049

Approvals

- Conforms to MSS SP-110
- ASME B31
- IAPMO/ANSI Z1157

Recommended Tools

For ½" to 2":

- Standard-size press tool (minimum hydraulic ram output of 7,200 lbs.)
- #56013 MegaPress jaw/ring kit (½" to 2")

For 2½" to 4":

- Standard-size press tool (minimum hydraulic ram output of 7,200 lbs.) for use with the PressBooster
- #26200 MegaPress XL PressBooster with 2½" press ring
- #57078 MegaPress XL 3" and 4" press ring kit
- #57081 Z3 Actuator with 2½" press ring (must be used with press gun with minimum 80mm press stroke)

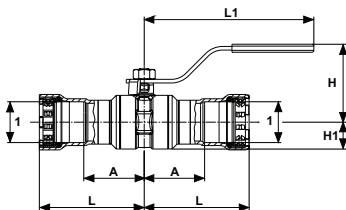

Part No.	Size (in)	A (in)	L (in)	L1 (in)	H (in)	H1 (in)
304 FKM 1						
29005	½	1.535	2.657	4.567	1.984	0.634
29010	¾	1.626	2.823	4.567	2.098	0.748
29015	1	1.811	3.197	5.766	2.465	0.878
29020	1¼	1.957	3.815	5.768	2.685	1.142
29025	1½	2.142	4.051	6.122	3.020	1.358
29030	2	2.382	4.390	6.122	3.315	1.654
86820	2½	3.717	5.516	11.087	5.142	2.256
86825	3	4.094	6.398	11.087	5.535	2.657
86830	4	4.638	7.843	13.055	6.697	3.346

Viega MegaPress 304 FKM 3-Piece Ball Valve, Models 4175.8, 4175.8XL

The MegaPress 304 FKM 3-piece stainless steel ball valve is equipped with a full port, 316 stainless steel 3-piece body and 304 stainless steel press ends. The ball valve features an FKM sealing element, a 420 stainless grip ring, a 304 stainless separator ring, PTFE stem seals, a locking metal handle, and Viega's Smart Connect technology for easy identification of unpressed connections during pressure testing.

Features

- 316 stainless steel ball
- Blowout-proof 316 stainless steel stem
- 304 stainless steel locking handle
- Adjustable packing nut
- Reinforced PTFE seats
- Smart Connect technology
- ISO 5211 mounting pad

Ratings

- Operating Temperatures: 14°F to 284°F (with temperature spikes up to 356°F)
- Max. Operating Pressure ½" to 2": 250 CWP
- Max. Operating Pressure 2½" to 4": 200 CWP

Valve Size (in)*	Valve Body Bolt & Nut Size		Bolt Torque +/- 5		Valve Stem Nut Size		Stem Nut	
			ft/lbs (Nm)	(10)	AF	mm	ft/lbs (Nm)	
½	M8 x 55	M8	7.5	(10)	AF 16 mm		7.5	10
¾	M8 x 65	M8	15	(20)	AF 18 mm		11	15
1	M10 x 75	M10	15	(20)	AF 21 mm		11	15
1¼	M10 x 90	M10	22.5	(30)	AF 22 mm		18.5	25
1½	M10 x 100	M10	22.5	(30)	AF 24 mm		18.5	25
2	M10 x 100	M10	22.5	(30)	AF 24 mm		18.5	25
2½	M12 x 140	M14	45	(60)	AF 30 mm	26	(35)	
3	M12 x 140	M14	45	(60)	AF 30 mm	26	(35)	
4	M12 x 140	M14	45	(60)	AF 30 mm	26	(35)	

*Sizes up to 3" have 4-bolt flanges; 4" has 6-bolt flanges.

Approvals

- Conforms to MSS SP-110
- ASME B31
- IAPMO/ANSI Z1157

Recommended Tools

For ½" to 2":

- Standard-size press tool (minimum hydraulic ram output of 7,200 lbs.)
- #56013 MegaPress jaw/ring kit (½" to 2")

For 2½" to 4":

- Standard-size press tool (minimum hydraulic ram output of 7,200 lbs.) for use with the PressBooster
- #26200 MegaPress XL PressBooster with 2½" press ring
- #57078 MegaPress XL 3" and 4" press ring kit
- #57081 Z3 Actuator with 2½" press ring (must be used with press gun with minimum 80mm press stroke)

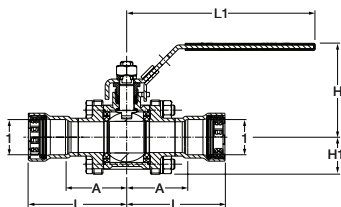

Part No.		Size (in)*	A (in)	L (in)	L1 (in)	H (in)	H1 (in)
304 FKM	316 EPDM	1					
86500	86530	½	1.72	2.80	5.88	2.85	1.04
86505	86535	¾	1.91	3.06	5.88	2.93	1.16
86510	86540	1	2.19	3.54	7.54	3.33	1.40
86515	86545	1¼	2.50	4.31	7.54	3.57	1.57
86520	86550	1½	2.92	4.79	7.54	3.89	1.83
86525	86555	2	3.09	5.07	7.54	3.89	1.83
86650	86665	2½	3.74	5.54	11.06	5.08	2.28
86655	86670	3	4.37	6.67	11.06	5.47	2.68
86660	86675	4	4.88	8.06	13.07	6.89	3.79

Sizes up to 3" have 4-bolt flanges; 4" has 6-bolt flanges.

Viega MegaPress 316 Ball Valve, Models 5170 and 5170XL

The MegaPress 316 stainless steel ball valve is equipped with a full port, 316 stainless steel 2-piece body and stainless steel press ends. The ball valve features an EPDM sealing element, a 420 stainless grip ring, a 304 stainless separator ring, EPDM stem seals, a locking stainless steel handle, and Viega's Smart Connect technology for easy identification of unpressed connections during pressure testing.

Features

- 316 stainless steel ball
- Body material designation: CF8 1.4408
- Blowout-proof 316 stainless steel stem
- 304 stainless steel locking handle
- Reinforced PTFE seats
- Smart Connect technology
- ISO 5211 mounting pad (for 2½", 3", and 4" only)

Ratings

- Temperature Range: 0°F to 250°F
- Max. Operating Pressure ½" to 2": 250 CWP
- Max. Operating Pressure 2½" to 4": 200 CWP

Valve Size (in)	Valve Stem Nut Size	Stem Nut		Cv (US gal/min)
		ft/lbs	(Nm)	
½	M8	3.7 to 7.5	5 to 10	15.5
¾	M8	3.7 to 7.5	5 to 10	33.4
1	M8	3.7 to 7.5	5 to 10	46.4
1¼	M8	3.7 to 7.5	5 to 10	93.5
1½	M8	3.7 to 7.5	5 to 10	124
2	M8	3.7 to 7.5	5 to 10	246
2½	M8	22.1 to 44.3	30 to 60	403
3	M8	22.1 to 44.3	30 to 60	606
4	M8	22.1 to 44.3	30 to 60	1,049

Approvals

- Conforms to MSS SP-110
- ASME B31
- IAPMO/ANSI Z1157
- NSF_®-61-372

Recommended Tools

For ½" to 2":

- Standard-size press tool (minimum hydraulic ram output of 7,200 lbs.)
- #56013 MegaPress jaw/ring kit (½" to 2")

For 2½" to 4":

- Standard-size press tool (minimum hydraulic ram output of 7,200 lbs.) for use with the PressBooster
- #26200 MegaPress XL PressBooster with 2½" press ring
- #57078 MegaPress XL 3" and 4" press ring kit
- #57081 Z3 Actuator with 2½" press ring (must be used with press gun with minimum 80mm press stroke)

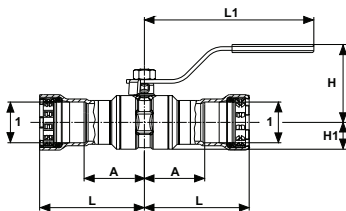

Part No.	Size (in)	A (in)	L (in)	L1 (in)	H (in)	H1 (in)
316 EPDM						
1						
28975	½	1.535	2.657	4.567	1.984	0.634
28980	¾	1.626	2.823	4.567	2.098	0.748
28985	1	1.811	3.197	5.766	2.465	0.878
28990	1¼	1.957	3.815	5.768	2.685	1.142
28995	1½	2.142	4.051	6.122	3.020	1.358
29000	2	2.382	4.390	6.122	3.315	1.654
86805	2½	3.717	5.516	11.087	5.142	2.256
86810	3	4.094	6.398	11.087	5.535	2.657
86815	4	4.638	7.843	13.055	6.697	3.346

Viega MegaPress 316 3-Piece Ball Valve, Models 5175.8, 5175.8XL

The MegaPress 316 3-piece stainless steel ball valve is equipped with a full port, 316 stainless steel 3-piece body, and stainless steel press ends. The ball valve features an EPDM sealing element, a 420 stainless steel grip ring, a 304 stainless separator ring, PTFE stem seals, a locking metal handle, and Viega's Smart Connect® technology for easy identification of unpressed connections during pressure testing.

Features

- 316 stainless steel ball
- Blowout-proof 316 stainless steel stem
- 304 stainless steel locking handle
- Adjustable packing nut
- Reinforced PTFE seats
- Smart Connect technology
- ISO 5211 mounting pad

Ratings

- Temperature Range: 0°F to 250°F
- Max. Operating Pressure ½" to 2": 250 CWP
- Max. Operating Pressure 2½" to 4": 200 CWP

Valve Size (in)*	Valve Body Bolt & Nut Size	Bolt Torque +/- 5 ft/lbs (Nm)	Valve Stem Nut Size	Stem Nut ft/lbs (Nm)
½	M8 x 55 M8	7.5 (10)	AF 16 mm	7.5 10
¾	M8 x 65 M8	15 (20)	AF 18 mm	11 15
1	M10 x 75 M10	15 (20)	AF 21 mm	11 15
1¼	M10 x 90 M10	22.5 (30)	AF 22 mm	18.5 25
1½	M10 x 100 M10	22.5 (30)	AF 24 mm	18.5 25
2	M10 x 100 M10	22.5 (30)	AF 24 mm	18.5 25
2½	M12 x 140 M14	45 (60)	AF 30 mm	26 (35)
3	M12 x 140 M14	45 (60)	AF 30 mm	26 (35)
4	M12 x 140 M14	45 (60)	AF 30 mm	26 (35)

*Sizes up to 3" have 4-bolt flanges; 4" has 6-bolt flanges.

Approvals

- Conforms to MSS SP-110
- ASME B31
- IAPMO/ANSI Z1157
- NSF 61-372

Recommended Tools

For ½" to 2":

- Standard-size press tool (minimum hydraulic ram output of 7,200 lbs.)
- #56013 MegaPress jaw/ring kit (½" to 2")

For 2½" to 4":

- Standard-size press tool (minimum hydraulic ram output of 7,200 lbs.) for use with the PressBooster
- #26200 MegaPress XL PressBooster with 2½" press ring
- #57078 MegaPress XL 3" and 4" press ring kit
- #57081 Z3 Actuator with 2½" press ring (must be used with press gun with minimum 80mm press stroke)

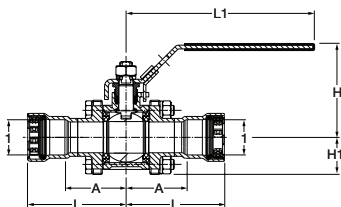

Part No.	Size (in)*	A (in)	L (in)	L1 (in)	H (in)	H1 (in)
304 FKM	316 EPDM	1				
86500	86530	½	1.72	2.80	5.88	2.85 1.04
86505	86535	¾	1.91	3.06	5.88	2.93 1.16
86510	86540	1	2.19	3.54	7.54	3.33 1.40
86515	86545	1¼	2.50	4.31	7.54	3.57 1.57
86520	86550	1½	2.92	4.79	7.54	3.89 1.83
86525	86555	2	3.09	5.07	7.54	3.89 1.83
86650	86665	2½	3.74	5.54	11.06	5.08 2.28
86655	86670	3	4.37	6.67	11.06	5.47 2.68
86660	86675	4	4.88	8.06	13.07	6.89 3.79

Sizes up to 3" have 4-bolt flanges; 4" has 6-bolt flanges.

Viega MegaPress 316 Check Valve, Model 5174

Viega's MegaPress 316 Check Valve is a spring check valve with a 316 stainless-steel body, stainless-steel spring, and MegaPress press ends. It is approved for potable water applications.

Features

- EPDM sealing element
- 0.5 psi cracking pressure
- Low pressure loss
- Silent operation
- Smart Connect technology

Ratings

- Temperature Range: 0°F to 250°F
- Max. Operating Pressure: 250

Approvals

- Conforms to MSS SP-110
- NSF[®]-61-372

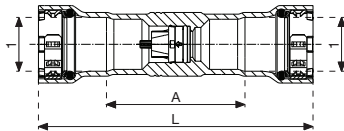

Approved Applications

- Hot and Cold Water
- Chilled Water
- Hydronic Heating Water

Pressure Drop

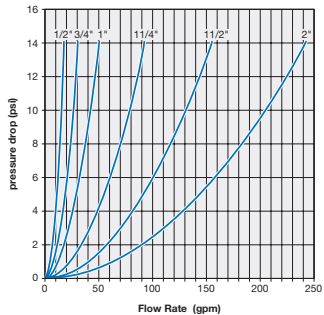

Part No.	Size (in)	A (in)	L (in)
316 EPDM	1		
29050	1/2	2.244	4.488
29055	3/4	2.323	4.685
29060	1	2.717	5.472
29065	1 1/4	2.992	6.732
29070	1 1/2	3.346	7.165
29075	2	3.937	7.953

Viega MegaPress Stainless 1/2" to 2" Fittings

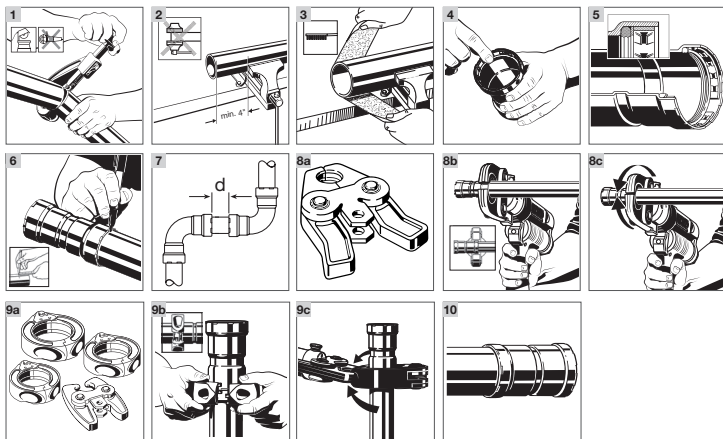

- 1** Cut piping at right angles using displacement-type cutter.
- 2** Keep end of pipe a minimum of 4" away from the contact area of the vise to prevent possible damage to the pipe.
- 3** Deburr inside and outside of the pipe and prep to proper insertion depth using a preparation tool or fine-grit sandpaper.
- 4** Check seal, separator ring, and grip ring for correct fit. Do not use oils or lubricants.
- 5** Illustration demonstrates proper fit of grip ring, separator ring, and sealing element.
- 6** Mark proper insertion depth. Improper insertion depth may result in an improper seal. It is recommended that the depth marking be visible on the completed assembly.

Minimum Insertion Depth for MegaPress						
Pipe Size	1/2"	3/4"	1"	1 1/4"	1 1/2"	2"
Insertion Depth	1 1/16"	1 3/16"	1 3/8"	1 9/16"	1 7/8"	2"

- 7** Refer to chart on page 18 for minimum distance between fittings. Failure to provide this distance may result in an improper seal. While turning slightly, slide fitting onto pipe to the marked depth. End of pipe must contact stop.

- 8a** Viega MegaPress Stainless 1/2" to 1" fitting connections must be performed with MegaPress jaws.

WARNING!
Keep extremities and foreign objects away from press tool during pressing operation to prevent injury or incomplete press.

- 8b** Open the MegaPress jaw and place at right angles on the fitting. Visually check insertion depth using mark on piping.
- 8c** Start pressing process and hold the trigger until the jaw has engaged the fitting.
- 9a** MegaPress Stainless 1 1/4" to 2" fitting connections must be performed with MegaPress rings and V2 actuator.
- 9b** Open MegaPress ring and place at right angles on the fitting. MegaPress ring must be engaged on the fitting bead. Check insertion depth.
- 9c** Place V2 actuator onto MegaPress ring and start pressing process. Hold the trigger until the actuator has engaged the MegaPress ring.
- 10** Remove MegaPress jaw from fitting or release V2 actuator from MegaPress ring and then remove MegaPress ring from the fitting. Remove control label to indicate press has been completed.

Viega MegaPress Stainless 2½" to 4" Fittings

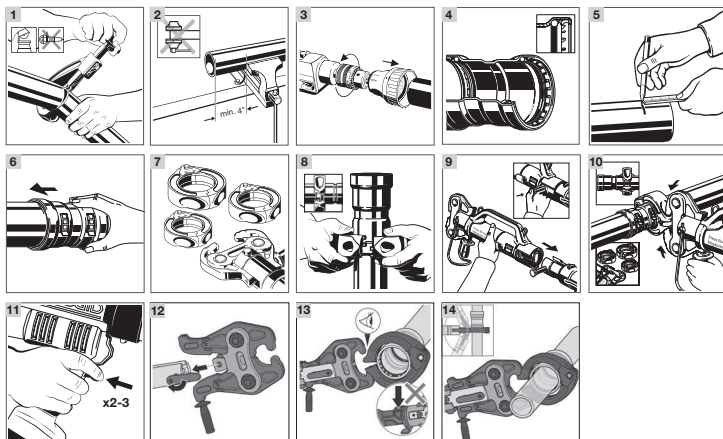

- 1** Cut piping at right angles using displacement-type cutter.
- 2** Keep end of pipe a minimum of 4" away from the contact area of the vise to prevent possible damage to the pipe in the press area.
- 3** Remove burr from inside and outside of piping and prep to proper insertion depth using a preparation tool or fine-grit sandpaper.
- 4** Check seal, separator ring, and grip ring for correct fit. Do not use oils or lubricants. Illustration demonstrates proper fit.
- 5** Mark proper insertion depth. Improper insertion depth may result in an improper seal. It is recommended that the depth marking be visible on the completed assembly.
- 6** While turning slightly, slide fitting onto pipe to the marked depth. End of pipe must contact stop.
- 7** Viega MegaPress Stainless 2½" to 4" fitting connections must be made using MegaPress XL rings and either the MegaPress XL PressBooster or the MegaPress Z3 actuator.
- 8** Open MegaPress ring and place at right angles on the fitting. The MegaPress XL ring must be engaged on the fitting bead. Check insertion depth.



WARNING!

Keep extremities and foreign objects away from press tool during pressing operation to prevent injury or incomplete press.

**Minimum Insertion Depth for
MegaPress 2½" to 4"**

Pipe Size	2½"	3"	4"
Insertion Depth	1 13/16"	2 5/16"	3 1/8"

- 6** While turning slightly, slide fitting onto pipe to the marked depth. End of pipe must contact stop.

Pressing with MegaPress XL PressBooster

- 9** Remove the retaining bolt of the press machine. Slide the PressBooster in via the press jaw fixture. Slide the retaining bolt of the press machine in as far as it will go.
- 10** To open the PressBooster jaw, pull back the handle at the hinged adapter jaw. Place PressBooster onto the MegaPress XL ring by inserting the ball heads of the hinged adapter jaw into the contact points of the XL ring. Push the handle forward to close the hinged adapter jaw.
- 11** Hold the trigger until the actuator has engaged the MegaPress XL ring. The PressBooster requires two presses of the trigger to execute a complete press. A third press may be needed to initiate a release cycle to reset the rollers back to the original position.

Pressing with MegaPress Z3 Actuator

- 12** On the press tool, rotate the retaining pin handle 180 degrees and pull it out to open the slot for the actuator. Insert the Viega Z3 actuator into the slot on the press tool. On the press tool, push the retaining pin back in and rotate it 180 degrees.
- 13** Open the Viega Z3 actuator by pulling the handle back. Place the open Viega Z3 actuator onto the MegaPress XL ring by inserting the ball heads of the actuator into the contact points of the XL ring. Close the Z3 actuator.
- 14** Start the pressing process by holding the press tool trigger until the actuator has engaged the XL ring. When the press cycle is complete, the actuator will stop and release.

Approved Applications

Media ¹	System Operating Conditions			Product Line, Material, and Sealing Element ²		
				MegaPress Stainless		
	Comments	Pressure	Temperature	304	316	
FKM				EPDM	FKM	
Water/Liquids						
Hot and Cold Potable Water	Test pressure 600 psi	200	See note ³		✓	
Rainwater / Graywater				✓	✓	✓
Chilled Water	≤50% Ethylene / Propylene glycol			✓	✓	✓
Hydronic Heating Water ⁹	≤50% Ethylene / Propylene glycol			✓	✓	✓
Treated Water	Fully desalinated, deionized, demineralized, distilled (open system)		32° to 250°	✓	✓	✓
Reverse Osmosis Water	<1 MΩ			✓	✓	✓
Paraffin Wax			Max 100°	✓		✓
Methyl Ethyl Ketone					✓	
Isopropyl Alcohol			Ambient ⁵	✓	✓	✓
Nitric Acid	Concentration ≤10%			✓	✓	✓
Phosphoric Acid	Concentration ≤25%				✓	✓
Fire Sprinkler	NFPA 13, 13D, 13R		175	✓	✓	✓
Steam	Low pressure		15	Max 250°	✓ ⁴	
	Residential	5	Max 227°	✓ ⁴	✓ ⁴	✓ ⁴
Fuels/Oils/Lubricants						
Ethanol	Pure grain alcohol	200	Ambient ⁵		✓	
Mineral Oil				✓		✓
Lube Oil ¹⁰	Petroleum based		Max 150°	✓		✓
Diesel Exhaust Fluid (DEF) ¹¹			See note ³ (10° minimum)	✓	✓	✓
Biodiesel ¹¹	ASTM D6751	140	Max 150°			✓
Heating Fuel Oil ¹¹		125	Max 100°	✓		✓
Diesel Fuel ¹¹				✓		✓
Kerosene ¹¹			Max 68°	✓		✓
Gear Oil	Lubricant		See note ³	✓		✓
Automatic Transmission Fluid				✓		✓
Hydraulic Oil				✓		✓
Engine Oil				✓		✓
Engine Coolant				✓	✓	✓
Waste Oil				✓		✓

Media ¹	System Operating Conditions			Product Line, Material, and Sealing Element ²		
				MegaPress Stainless		
	Comments	Pressure	Temperature	304	316	FKM
Gases						
Compressed Air	Oil Concentration ≤ 25 mg/m ³	200	Max 140°	✓	✓	✓
	Oil Concentration > 25 mg/m ³			✓		✓
Nitrogen - N ₂				✓	✓	✓
Carbon Dioxide - CO ₂	Dry			✓	✓	✓
Argon - Ar				✓	✓	✓
Ammonia	Anhydrous			Max 120°		✓
	Ammonia environment ⁷	✓	✓		✓	
Oxygen - O ₂	Non-medical Keep free of oil and grease	140	Max 140°		✓	
Hydrogen - H ₂		125		✓	✓	✓
Acetylene	Test pressure 350 psi	20	Ambient ⁵	✓	✓	✓
Vacuum	Minimum absolute pressure Maximum differential pressure	750 μ m Hg 29.2" Hg	Max 160°	✓	✓	✓
Special Media						
Methanol		200	75°		✓	
Latex Paint			32° to 250°		✓	✓
Urea Solution	Concentration $\leq 40\%$	140	100°		✓	
Caustic Soda	Concentration $\leq 50\%$		140°		✓	
Acetone	Liquid	70	-14° to 104°		✓	

¹ It is recommended that all systems be clearly labeled with the media being conveyed. For further information please consult Viega Technical Services.

² All Viega systems must be used with the manufacturer's recommended sealing element. Contact your local Viega representative or Viega Technical Services for specific application temperature, pressure, and concentration limits.

³ System pressure and temperature ranges depend on sealing element. Any ranges listed above will be overruled by the sealing element limits here:

^{3a} EPDM temperature ranges are typically 0°F to 250°F.

^{3b} FKM temperature ranges are typically 14°F to 284°F with temperature spikes (24hr) up to 356°F.

⁴ System must contain adequate condensate drainage.

⁵ Ambient temperatures should be taken as normal operating conditions for the applications not to exceed sealing element limitations.

⁶ Compliant with CSA 6.32 / ANSI LC-4.

⁷ All copper or copper alloy components that are exposed in ammonia environments require lacquer or paint coating.

⁹ It is a Viega engineering best practice that for heating applications using EPDM, where the media will be running continuously, non-stop at 200°F or above, to consider switching to an FKM sealing element.

¹¹ Not approved for use in Canada.

Sealing Element Description

FKM Sealing Element

MegaPress 304 and 316 FKM press fittings are manufactured with an FKM sealing element installed at the factory. FKM is well known for its excellent resistance to petroleum products and solvents as well as for its exceptional high-temperature performance, which makes it ideal for seals and gaskets in solar, district heating, low-pressure steam, and compressed-air systems.

Definition: FKM

Fluoroelastomer, dull black in color

Maximum Pressure: 200 psi

Operating Temperature: 14°F to 284°F (with temperature spikes up to 356°F)

The FKM sealing element is a special-purpose elastomer typically installed where higher temperatures are required. It possesses excellent resistance to aging, ozone, sunlight, weathering, environmental influences, and oils and petroleum-based additives.

EPDM Sealing Element

MegaPress 316 press fittings are manufactured with an EPDM sealing element installed at the factory. The EPDM sealing element is used mainly for potable water, hydronic heating, low pressure steam, fire sprinkler, and compressed-air installations.

Definition: EPDM

Ethylene-Propylene-Diene-Monomer, gloss black in color

Maximum Pressure: 200 psi

Operating Temperature: 0°F to 250°F

The EPDM sealing element is a synthetically manufactured and peroxidically cross-linked, general-purpose elastomer with a wide range of applications. It is resistant to aging, ozone, sunlight, weathering, environmental influences, chemicals, and most alkaline solutions.

The EPDM sealing element is used mainly in the applications of hydronic heating, chilled water, and fire sprinkler installations. It is not resistant to hydrocarbon solvent solutions, oils, chlorinated hydrocarbons, turpentine, or gasoline.

Viega MegaPress Stainless Steel Pipe Marking Guide

Guide to the ANSI A13.1 Standard for the Identification of Pipes

Viega MegaPress stainless ½" to 4" fittings are compatible with ASTM A312 stainless steel-pipe. All Viega MegaPress stainless piping systems should be continuously marked in accordance with ANSI A13.1 or as required by the local authority having jurisdiction.

Usage	Material Properties	Type of Application (typical)	Color Scheme
Hazardous Materials	<ul style="list-style-type: none"> ■ Flammable or Explosive ■ Chemically Active or Toxic ■ Radioactive ■ Extreme Temperature/ Pressure 	<ul style="list-style-type: none"> ■ Process Piping ■ High-Pressure Steam ■ Acids/Corrosives 	YELLOW ON BLACK
Low Hazard Materials (Liquid)	<ul style="list-style-type: none"> ■ Liquid ■ Liquid Admixture 	<ul style="list-style-type: none"> ■ Cooling Water ■ Grey Water ■ Chilled Water 	WHITE ON GREEN
Low Hazard Materials (Gas)	<ul style="list-style-type: none"> ■ Gas ■ Gas Admixture 	<ul style="list-style-type: none"> ■ Compression Air ■ Nitrogen (N₂) ■ Argon (Ar) 	WHITE ON BLUE
Fire Suppression	<ul style="list-style-type: none"> ■ Liquid ■ Gas ■ Foam 	<ul style="list-style-type: none"> ■ Sprinklers (Wet/Dry) ■ CO₂ ■ Foam (AFFF) 	WHITE ON RED

Marker Placement

- At all changes in direction
- At both sides of any penetrations (valves, flanges, tees, etc.)
- At frequent intervals on straight run (50 feet is typical)
- Locate pipe markers so they are readily visible
- Provide arrows indicating direction of flow

Pipe O.D. Including Covering		Minimum Length of Label Field Color		Minimum Height of Letters	
(in)	(mm)	(in)	(mm)	(in)	(mm)
¾ to 1¼	19 to 32	8	203	½	13
1½ to 2	38 to 51	8	203	¾	19
2½ to 4	64 to 102	12	305	1¼	32



This guide is for general information purposes only. Pipe markings shall be in accordance with local code requirements.

No-Stop Couplings

No-stop couplings and extended no-stop couplings are often used to conduct repairs. Without a stop, these couplings can slide completely onto a pipe and allow a connection to be made in tighter spaces. Unlike fittings with an integrated stop that have a minimum insertion depth, no-stop couplings have minimum and maximum allowable insertion depths.

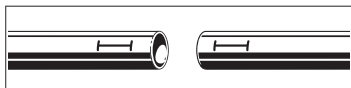

Viega MegaPress Stainless No-Stop Couplings

Pipe Diameter (in)	Minimum Insertion		Maximum Insertion	
	(in)	(mm)	(in)	(mm)
1/2	1 1/16	27	1 5/8	41
3/4	1 3/16	30	1 13/16	46
1	1 3/8	35	1 15/16	49
1 1/4	1 13/16	46	2 1/2	64
1 1/2	1 7/8	48	2 3/4	70
2	2	51	2 3/4	70
2 1/2	1 13/16	46	3 3/8	79
3	2 5/16	59	3 11/16	94
4	3 1/8	80	4 3/8	111

Welding

The following requirements must be considered when welding in the same vicinity as Viega MegaPress stainless fittings.

Welding Requirements

The installer should take precautions to keep the MegaPress stainless connection cool:

- Wrap the connection with a cold, wet rag.
- Protect the connection with a weld blanket.
- Prefabricate solder connections/welded fittings prior to installing the press fitting. (Ensure pipe has cooled before installing the press fitting.)
- Apply heat sink gel or spray or spot freezing.

Welding Adjacent to a Press Fitting

To prevent damage to the sealing element, maintain proper welding distances from the fitting. If welding adjacent to the connection, weld a minimum of four inches away.

Welding in Line With a Press Fitting

To prevent damage to the sealing element, maintain proper welding distances from the fitting. If welding in line with the connection, weld a minimum of three feet away from the connection to protect the sealing element.

Minimum Distance Between MegaPress Connections

Pipe Diameter (in)	Minimum Distance	
	(in)	(mm)
1/2	1/4	7
3/4	1/4	7
1	1/4	7
1 1/4	1/2	13
1 1/2	1/2	13
2	1/2	13
2 1/2	1/2	13
3	1/2	13
4	1/2	13

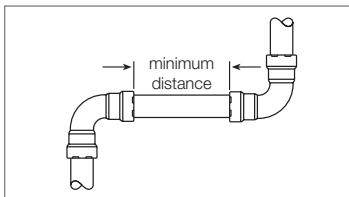

General Installation Notes

Expansion

Thermal expansion in installed systems generates stress on pipes and appliance connectors. Compensation must be allowed for expansion and contraction that may occur within the piping system. Expansion joints or mechanical expansion compensators may be used to alleviate these stresses.

Electrical Bonding

When properly installed, MegaPress stainless fittings comply with Section 1211.15 Electrical Bonding and Grounding of the Uniform Plumbing Code.

The mechanical press provides continuous metal-to-metal contact between fitting and pipe. The press ensures the continuity of the bonding through this contact.



DANGER! **Electric Shock**

An electric shock can cause burns, serious injury, and even death.

- Because all metallic piping can conduct electricity, unintentional contact with a live wire can cause the entire system and components connected to it to become energized. Metal piping is not meant to conduct electricity.

- A properly bonded system creates a safe path for electricity to travel so that the system can't be energized.

- An unbonded or improperly bonded system can be a shock hazard.

- Always ensure that bonding is in accordance with local codes.

Concealed Spaces

The Viega MegaPress Stainless fitting system has been approved for use in concealed spaces. Specific performance tests were conducted to evaluate the fittings for use in concealed spaces. Concealed pipe and fittings shall be protected from puncture threats.

Exposure to Freezing Temperatures

Viega MegaPress 316 systems with EPDM sealing elements can be installed in ambient temperatures down to 0°F. The FKM sealing element available with Viega MegaPress 304 and 316 FKM fittings can be installed in ambient temperatures down to 14°F. When the contents could freeze, piping must be protected per acceptable engineering practices, codes, and as required by local code.

Underground Installations

Viega MegaPress stainless fitting systems and stainless pipe are approved for underground installations. However, installations must meet all state and local codes, including those for underground. Proper authorization must be obtained from the Authority Having Jurisdiction prior to installation.

Corrosion Protection

Viega MegaPress stainless fittings exposed to corrosive action, such as soil conditions or moisture, must be protected in an approved manner in accordance with NACE Standard RP0169-2002 Section 5, 2009 UPC Chapter 6 Section 609.3.1, 2009 UMC Chapter 13 Section 1312.1.3, and in a manner satisfactory to local code requirements. Care should be taken to select hangers of suitable material that is galvanically compatible with the piping system. In addition, systems should be properly sized to minimize the risk of erosion corrosion resulting from excessive velocities.

Pressure Surges

- Pressure surges or transients from fast-acting valves, pump surges, and other sources that result in water hammer may cause damage to many system components, including press fittings.

- When fast-acting valves and/or pumps are incorporated into a system, the designer and installer should isolate press fittings from sharp pressure surges.

Transition Fittings – Threaded

Viega MegaPress stainless systems can be joined with off-the-shelf threaded fittings made of non-ferrous metals. In this regard:

- The threaded connection is made first.
 - The press connection is made second.
- This process avoids unnecessary torsion on the press fitting.

Transition Fittings – Flange

When using Viega flanges, bolt the flange end in place prior to pressing the fitting to the pipe.

Rotating a Pressed Fitting

Once a MegaPress stainless fitting has been pressed, it can be rotated (not by hand), but once rotated more than five degrees, the fitting should be re-pressed to restore resistance to rotational movement.

Deflection

The pressing process can cause deflection (angular misalignment) to occur. When pressing Viega MegaPress stainless fittings in a system, the deformation of the fitting is constant. This allows for a consistent leak-free joint every time and is a result of the pressing technique.

Deflection occurs in the same way for every fitting. The fitting being pressed will move in the direction of the jaw or ring opening.

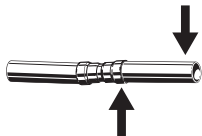

- Since the fitting will deflect toward the opening of the jaw or ring, the pipe end will deflect in the opposite direction.
- By counteracting the fitting movement, one can minimize the deflection of the fitting and ultimately the pipe.
- When using strut and clamps, deflection is minimized and nearly eliminated, depending on clamp spacing.

Controlling Deflection

Deflection while pressing can be minimized by utilizing the following installation practices.

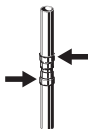

Alternate Press Directions

- Press one end of fitting.
- Make second press on other end of fitting from the opposite side.

Push-Pull Method

- Rings = Push on press tool.
 - Jaws = Pull on press tool.
- The press tool can be feathered using the trigger as needed to apply pulling or pushing force to control deflection.

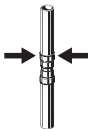
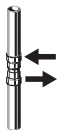

Re-Press

- Press the fitting, once on each side (that is, re-press the fitting a second time on the opposite side).
- Pressing the same connection from the opposite side will usually straighten misalignment between the pipe and fitting.

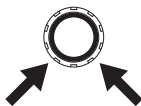

- When pressing overhead piping, it may be inconvenient to alternate sides for each press.
- The natural weight of the piping plus pressing on opposite sides at a 45-degree angle should adequately eliminate deflection.
- This technique can also be used for any horizontal piping and when working above the piping.

Tool Clearances

Minimum distances should be taken into consideration during planning in order to avoid space constraints during installation.

Ensure that the space required for system pressing tools is available if Viega MegaPress stainless fittings will be installed immediately upstream or downstream from wall or floor penetrations.

MegaPress Distance Requirements for Press Jaws Between Pipes and Walls

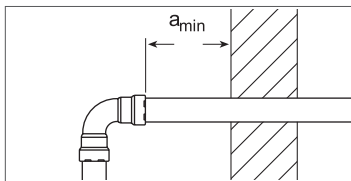

Pipe Diameter	Minimum space requirement, a_{min} for press tools
	RIDGID RP 330-B, 330-C, and 340-B Press Tool
½" to 1"	1½"
1¼" to 2"	¾"
2½" to 4"	¾"

MegaPress Standard Jaws Clearance

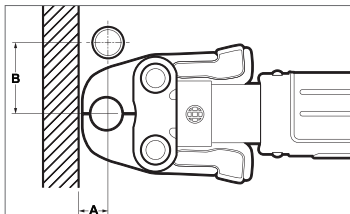

Pipe Diameter	A minimum	B minimum
½"	1"	2½"
¾"	1¼"	3½"
1"	1¾"	3½"

MegaPress Compact Jaws Clearance

Pipe Diameter	A minimum	B minimum
½"	1¼"	2½"
¾"	1½"	3"

MegaPress Standard Jaws Clearance Between Pipe, Wall, and Floor

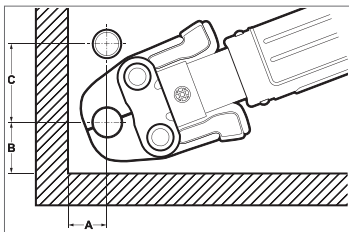

Pipe Diameter	A minimum	B minimum	C minimum
½"	1¼"	1⅞"	3"
¾"	1½"	2⅛"	3½"
1"	2"	2½"	4"

MegaPress Compact Jaws Clearance Between Pipe, Wall, and Floor

Pipe Diameter	A minimum	B minimum	C minimum
½"	1½"	2⅛"	3⅞"
¾"	1⅞"	2⅛"	3⅞"

MegaPress Rings Dimensions

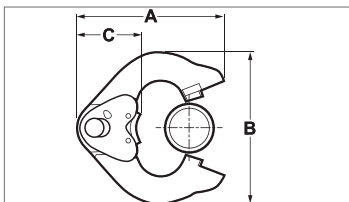

Pipe Diameter	A minimum	B minimum	C minimum
1¼"	6"	6¼"	2½"
1½"	6"	6¾"	2⅝"
2"	6"	6⅞"	2½"
2½"	6⅝"	7"	2½"
3"	7½"	8⅞"	2½"
4"	8½"	10⅝"	2⅝"

MegaPress Rings with V2/V3 Actuator Clearance

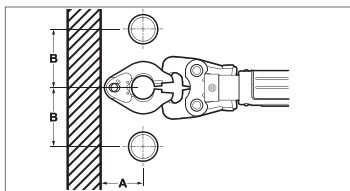

Pipe Diameter	A minimum	B minimum
1¼"	3¾"	4⅞"
1½"	4"	5⅞"
2"	4"	5⅞"
2½"	4½"	5⅞"
3"	4¾"	6¾"
4"	5⅞"	8¼"

MegaPress Rings with V2/V3 Actuator Clearance Between Pipe, Wall, and Floor

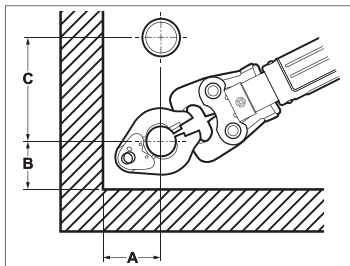

Pipe Diameter	A minimum	B minimum	C minimum
1¼"	3¾"	3¾"	4⅞"
1½"	4"	4"	5⅞"
2"	4"	4"	5⅞"
2½"	4½"	4"	5⅞"
3"	4¾"	4¾"	6¾"
4"	5⅞"	5½"	8¼"

Pressing with Ring and Actuator in Tight Quarters

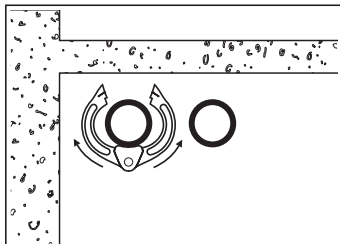

1. Wrap the actuator ring around the press fitting with the opening facing away from you.

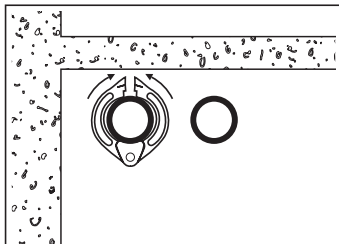

2. Close the actuator tight around the fitting.

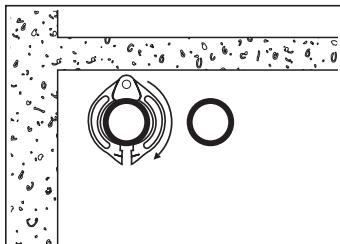

3. Rotate the actuator ring until the press jaw receptacle is facing toward you.

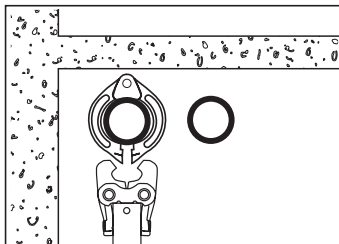

4. Properly insert press jaws and begin the press procedure.

Dimensional Documentation
MegaPress Stainless



MegaPress 90° Elbow, Stainless Steel, P x P – Models 4116 / 5116 / 6816

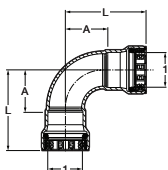

Part No.			Size (in)		A (in)		L (in)	
304 FKM	316 EPDM	316 FKM	1	Dec	Frac	Dec	Frac	
95005	90005	91695	½	1.13	1⅛	2.24	2¼	
95010	90010	91700	¾	1.32	1⅝	2.52	2½	
95015	90015	91705	1	1.69	1⅞	3.07	3⅜	
95785	90835	91710	1¼	1.96	1⅝	3.82	3⅜	
95020	90020	91715	1½	2.22	2¼	4.13	4⅛	
95025	90025	91720	2	2.76	2¾	4.76	4¾	

MegaPress Stainless 90° Elbow P x P – Models 4116XL / 5116XL / 6816XL

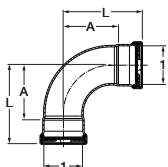

Part No.			Size (in)		A (in)		L (in)	
304 FKM	316 EPDM	316 FKM	1	Dec	Frac	Dec	Frac	
95500	90500	98405	2½	4.15	4⅛	5.94	5⅝	
95505	90505	98410	3	4.76	4¾	7.09	7⅜	
95510	90510	98415	4	6.00	6	9.17	9⅜	

MegaPress 90° Elbow, Stainless Steel, FTG x P – Models 4116.1 / 5116.1 / 6816.1

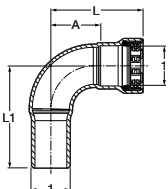

Part No.			Size (in)		A (in)		L (in)		L1 (in)	
304 FKM	316 EPDM	316 FKM	1	Dec	Frac	Dec	Frac	Dec	Frac	
95030	90030	91725	½	1.13	1⅛	2.24	2¼	2.56	2⅞	
95035	90035	91730	¾	1.32	1⅝	2.52	2½	2.80	2⅞	
95040	90040	91735	1	1.69	1⅞	3.07	3⅜	3.39	3⅝	
95845	90895	91740	1¼	1.96	1⅝	3.82	3⅜	4.04	4⅜	
95045	90045	91745	1½	2.22	2¼	4.13	4⅛	4.21	4⅜	
95050	90050	91750	2	2.76	2¾	4.76	4¾	5.08	5⅜	

MegaPress Stainless 90° Street Elbow P x FTG – Models 4116.1XL / 5116.1XL / 6816.1XL

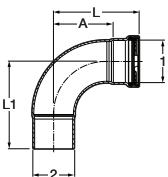

Part No.			Size (in)		A (in)		L (in)		L1 (in)	
304 FKM	316 EPDM	316 FKM	1	2	Dec	Frac	Dec	Frac	Dec	Frac
95515	90515	98390	2½ x 2½		4.15	4⅛	5.94	5⅝	6.06	6⅜
95520	90520	98395	3 x 3		4.76	4¾	7.09	7⅜	6.81	6⅜
95525	90525	98400	4 x 4		6.00	6	9.17	9⅜	8.78	8¾

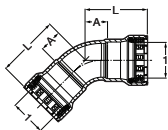
MegaPress 45° Elbow, Stainless Steel, P x P – Models 4126 / 5126 / 6826

Part No.			Size (in)		A (in)		L (in)	
304 FKM	316 EPDM	316 FKM	1	Dec	Frac	Dec	Frac	
95055	90055	91755	1/2	0.56	9/16	1.67	1 11/16	
95060	90060	91760	3/4	0.67	11/16	1.87	1 7/8	
95065	90065	91765	1	0.82	13/16	2.20	2 3/16	
95790	90840	91770	1 1/4	0.94	15/16	2.80	2 13/16	
95070	90070	91775	1 1/2	1.08	1 1/16	2.99	3	
95075	90075	91780	2	1.28	1 1/4	3.29	3 5/16	

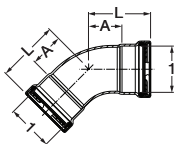
MegaPress Stainless 45° Elbow P x P – Models 4126XL / 5126XL / 6826XL

Part No.			Size (in)		A (in)		L (in)	
304 FKM	316 EPDM	316 FKM	1	Dec	Frac	Dec	Frac	
95530	90530	98510	2 1/2	2.10	2 1/8	3.90	3 7/8	
95535	90535	98515	3	2.26	2 1/4	4.56	4 9/16	
95540	90540	98520	4	2.74	2 3/4	5.89	5 7/8	

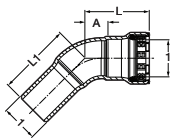
MegaPress 45° Elbow, Stainless Steel, FTG x P – Models 4126.1 / 5126.1 / 6826.1

Part No.			Size (in)		A (in)		L (in)		L1 (in)	
304 FKM	316 EPDM	316 FKM	1	Dec	Frac	Dec	Frac	Dec	Frac	
95080	90080	91785	1/2	0.56	9/16	1.67	1 11/16	1.97	1 15/16	
95085	90085	91790	3/4	0.67	11/16	1.87	1 7/8	2.13	2 1/8	
95090	90090	91795	1	0.82	13/16	2.20	2 3/16	2.52	2 1/2	
95850	90900	91800	1 1/4	0.94	15/16	2.80	2 13/16	2.99	3	
95095	90095	91805	1 1/2	1.08	1 1/16	2.99	3	3.07	3 1/16	
95100	90100	91810	2	1.28	1 1/4	3.29	3 5/16	3.58	3 9/16	

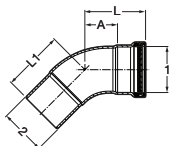
MegaPress Stainless 45° Street Elbow P x FTG – Models 4126.1XL / 5126.1XL / 6826.1XL

Part No.			Size (in)		A (in)		L (in)		L1 (in)	
304 FKM	316 EPDM	316 FKM	1	2	Dec	Frac	Dec	Frac	Dec	Frac
95545	90545	98495	2 1/2 x 2 1/2		2.10	2 1/8	3.90	3 7/8	3.95	3 15/16
95550	90550	98500	3 x 3		2.26	2 1/4	4.56	4 9/16	4.34	4 5/16
95555	90555	98505	4 x 4		2.74	2 3/4	5.89	5 7/8	5.62	5 5/8

MegaPress Tee, Stainless Steel, P x P x P – Models 4118 / 5118 / 6818

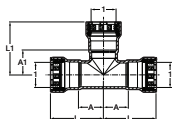

Part No.			Size (in)		A (in)		A1 (in)		L (in)		L1 (in)		
304 FKM	316 EPDM	316 FKM	1		Dec		Frac		Dec		Frac		
95105	90105	91600	½		0.97	1		0.93	15/16		2.08	2 1/16	
95110	90110	91605	¾		1.09	1 1/16		1.05	1 1/16		2.29	2 5/16	
95115	90115	91610	1		1.24	1 ¼		1.20	1 5/16		2.63	2 5/8	
95795	90845	91640	1 ¼		1.41	1 7/16		1.31	1 5/16		3.27	3 ¼	
95120	90120	91615	1 ½		1.57	1 9/16		1.56	1 9/16		3.48	3 ½	
95125	90125	91620	2		1.81	1 13/16		1.76	1 ¾		3.82	3 13/16	

MegaPress Stainless Tee P x P x P – Models 4118XL / 5118XL / 6818XL

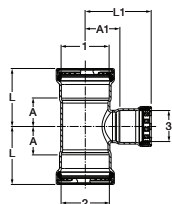

Part No.			Size (in)			A (in)		A1 (in)		L (in)		L1 (in)		
304 FKM	316 EPDM	316 FKM	1	2	3	Dec		Frac		Dec		Frac		
95575	90575	98450	2 ½ x 2 ½ x 1 ½			1.72	1 ¾		2.08	2 1/16		3.52	3 ½	
95580	90580	98455	2 ½ x 2 ½ x 2			2.16	2 5/16		2.05	2 1/16		3.96	3 15/16	
95560	90560	98435	2 ½ x 2 ½ x 2 ½			2.16	2 5/16		2.26	2 ¼		3.96	3 15/16	
95590	90590	98465	3 x 3 x 1 ½			1.80	1 13/16		2.33	2 5/16		4.13	4 1/8	
95585	90585	98460	3 x 3 x 2			2.11	2 1/8		2.30	2 5/16		4.41	4 7/16	
95595	90595	98470	3 x 3 x 2 ½			2.32	2 5/16		2.51	2 ½		4.63	4 5/8	
95565	90565	98440	3 x 3 x 3			2.55	2 5/16		2.52	2 ½		4.88	4 7/8	
95600	90600	98475	4 x 4 x 1 ½			1.86	1 7/8		2.90	2 5/8		5.04	5 1/16	
95605	90605	98480	4 x 4 x 2			2.18	2 5/16		2.87	2 5/8		5.35	5 3/8	
95610	90610	98485	4 x 4 x 2 ½			2.40	2 5/8		3.08	3 1/16		5.55	5 9/16	
95615	90615	98490	4 x 4 x 3			2.66	2 7/16		3.13	3 1/8		5.81	5 ¾	
95570	90570	98445	4 x 4 x 4			3.22	3 ¼		3.08	3 1/16		6.40	6 3/8	

MegaPress Reducing Tee, Stainless Steel, P x P x P – Models 4118 / 5118 / 6818

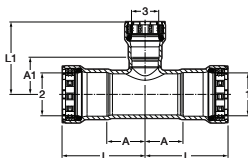

Part No.			Size (in)			A (in)		A1 (in)		L (in)		L1 (in)	
304 FKM	316 EPDM	316 FKM	1	2	3	Dec	Frac	Dec	Frac	Dec	Frac	Dec	Frac
95130	90130	91625	¾ x ¾ x ½			1.09	1 ¹ / ₁₆	1.02	1	2.29	2 ⁵ / ₁₆	2.13	2 ¹ / ₈
95135	90135	91630	1 x 1 x ½			1.24	1 ¹ / ₄	1.17	1 ³ / ₁₆	2.63	2 ⁵ / ₈	2.28	2 ¹ / ₄
95140	90140	91635	1 x 1 x ¾			1.24	1 ¹ / ₄	1.20	1 ³ / ₁₆	2.63	2 ⁵ / ₈	2.40	2 ³ / ₈
95855	90905	91645	1¼ x 1¼ x ½			1.41	1 ⁷ / ₁₆	1.31	1 ⁵ / ₁₆	3.27	3 ¹ / ₄	2.42	2 ⁷ / ₁₆
95860	90910	91650	1¼ x 1¼ x ¾			1.41	1 ⁷ / ₁₆	1.35	1 ³ / ₈	3.27	3 ¹ / ₄	2.55	2 ⁹ / ₁₆
95865	90915	91655	1¼ x 1¼ x 1			1.41	1 ⁷ / ₁₆	1.34	1 ³ / ₈	3.27	3 ¹ / ₄	2.73	2 ³ / ₄
95145	90145	91660	1½ x 1½ x ½			1.57	1 ⁹ / ₁₆	1.42	1 ⁷ / ₁₆	3.48	3 ¹ / ₂	2.53	2 ¹ / ₂
95150	90150	91665	1½ x 1½ x ¾			1.57	1 ⁹ / ₁₆	1.46	1 ⁷ / ₁₆	3.48	3 ¹ / ₂	2.65	2 ⁵ / ₈
95155	90155	91670	1½ x 1½ x 1			1.57	1 ⁹ / ₁₆	1.45	1 ⁷ / ₁₆	3.48	3 ¹ / ₂	2.84	2 ¹³ / ₁₆
NA	NA	91910	1½ x 1½ x 1¼			1.57	1 ⁹ / ₁₆	1.50	1 ¹ / ₂	3.48	3 ¹ / ₂	3.36	3 ³ / ₈
95160	90160	91675	2 x 2 x ½			1.81	1 ¹³ / ₁₆	1.72	1 ³ / ₄	3.82	3 ¹³ / ₁₆	2.83	2 ¹³ / ₁₆
95165	90165	91680	2 x 2 x ¾			1.81	1 ¹³ / ₁₆	1.74	1 ³ / ₄	3.82	3 ¹³ / ₁₆	2.93	2 ¹⁵ / ₁₆
95170	90170	91685	2 x 2 x 1			1.81	1 ¹³ / ₁₆	1.70	1 ¹¹ / ₁₆	3.82	3 ¹³ / ₁₆	3.09	3 ¹ / ₁₆
NA	NA	91915	2 x 2 x 1¼			1.81	1 ¹³ / ₁₆	1.81	1 ¹³ / ₁₆	3.82	3 ¹³ / ₁₆	3.67	3 ¹¹ / ₁₆
95175	90175	91690	2 x 2 x 1½			1.81	1 ¹³ / ₁₆	1.80	1 ¹³ / ₁₆	3.82	3 ¹³ / ₁₆	3.71	3 ¹¹ / ₁₆

MegaPress Reducing Tee, Stainless Steel, P x P x FPT – Models 4117.2 / 5117.2 / 6817.2

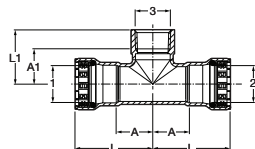

Part No.			Size (in)			A (in)		A1 (in)		L (in)		L1 (in)	
304 FKM	316 EPDM	316 FKM	1	2	3	Dec	Frac	Dec	Frac	Dec	Frac	Dec	Frac
95180	90180	91845	¾ x ¾ x ½			1.09	1 ¹ / ₁₆	1.01	1	2.29	2 ⁵ / ₁₆	1.54	1 ⁹ / ₁₆
95185	90185	91850	¾ x ¾ x ¾			1.09	1 ¹ / ₁₆	1.02	1	2.29	2 ⁵ / ₁₆	1.58	1 ⁹ / ₁₆
95190	90190	91855	1 x 1 x ½			1.24	1 ¹ / ₄	1.17	1 ³ / ₁₆	2.63	2 ⁵ / ₈	1.70	1 ¹¹ / ₁₆
95195	90195	91860	1 x 1 x ¾			1.24	1 ¹ / ₄	1.17	1 ³ / ₁₆	2.63	2 ⁵ / ₈	1.73	1 ³ / ₄
NA	NA	91865	1¼ x 1¼ x ½			1.41	1 ⁷ / ₁₆	1.33	1 ⁵ / ₁₆	3.27	3 ¹ / ₄	1.87	1 ⁷ / ₈
NA	NA	91870	1¼ x 1¼ x ¾			1.41	1 ⁷ / ₁₆	1.33	1 ⁵ / ₁₆	3.27	3 ¹ / ₄	1.89	1 ⁷ / ₈
NA	NA	91875	1¼ x 1¼ x 1			1.41	1 ⁷ / ₁₆	1.48	1 ¹ / ₂	3.27	3 ¹ / ₄	2.14	2 ¹ / ₈
95200	90200	91880	1½ x 1½ x ½			1.57	1 ⁹ / ₁₆	1.40	1 ³ / ₈	3.48	3 ¹ / ₂	1.94	1 ¹⁵ / ₁₆
95205	90205	91885	1½ x 1½ x ¾			1.57	1 ⁹ / ₁₆	1.41	1 ⁷ / ₁₆	3.48	3 ¹ / ₂	1.96	1 ¹⁵ / ₁₆
95210	90210	91890	1½ x 1½ x 1			1.57	1 ⁹ / ₁₆	1.55	1 ⁹ / ₁₆	3.48	3 ¹ / ₂	2.21	2 ³ / ₁₆
95215	90215	91895	2 x 2 x ½			1.81	1 ¹³ / ₁₆	1.72	1 ³ / ₄	3.82	3 ¹³ / ₁₆	2.26	2 ¹ / ₄
95220	90220	91900	2 x 2 x ¾			1.81	1 ¹³ / ₁₆	1.70	1 ¹¹ / ₁₆	3.82	3 ¹³ / ₁₆	2.26	2 ¹ / ₄
95225	90225	91905	2 x 2 x 1			1.81	1 ¹³ / ₁₆	1.89	1 ⁷ / ₈	3.82	3 ¹³ / ₁₆	2.55	2 ⁹ / ₁₆

MegaPress Stainless Tee P x P x FPT – Models 4117.2XL / 5117.2XL / 6817.2XL

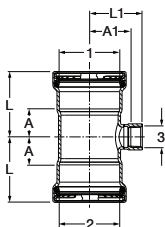

Part No.			Size (in)			A (in)		A1 (in)		L (in)		L1 (in)	
304 FKM	316 EPDM	316 FKM	1	2	3	Dec	Frac	Dec	Frac	Dec	Frac	Dec	Frac
95620	90620	98420	2½ x 2½ x ¾			1.35	1¾	2.00	2	3.15	3⅛	2.55	2⅝
95625	90625	98425	3 x 3 x ¾			1.44	1⅞	2.24	2¼	3.74	3¾	2.80	2⅞
95630	90630	98430	4 x 4 x ¾			1.55	1⅞	2.76	2¾	4.72	4¾	3.31	2⅞

MegaPress Adapter, Stainless Steel, P x MPT – Models 4111 / 5111 / 6811

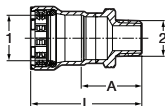

Part No.			Size (in)			A (in)		L (in)	
304 FKM	316 EPDM	316 FKM	1	2	Dec	Frac	Dec	Frac	
95230	90230	91205	½ x ½		1.42	1⅞	2.53	2½	
95235	90235	91210	¾ x ½		1.43	1⅞	2.63	2⅝	
95240	90240	91215	¾ x ¾		1.46	1⅞	2.66	2⅞	
95245	90245	91220	1 x 1		1.63	1⅝	3.02	3	
95830	90880	91225	1¼ x 1¼		1.85	1⅞	3.70	3⅞	
95250	90250	91230	1½ x 1½		1.92	1⅞	3.73	3¾	
95255	90255	91235	2 x 2		1.89	1⅞	3.90	3⅞	

MegaPress Stainless Adapter P x MPT – Models 4111XL / 5111XL / 6811XL

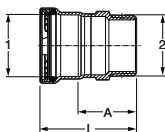

Part No.			Size (in)			A (in)		L (in)	
304 FKM	316 EPDM	316 FKM	1	2	Dec	Frac	Dec	Frac	
95635	90635	98300	2½ x 2½			2.75	2¾	4.55	4⅞
95640	90640	98305	3 x 3			2.89	2⅞	5.20	5⅞
95735	90735	98310	4 x 4			3.03	3	6.21	6⅞

MegaPress Adapter, Stainless Steel, P x FPT – Models 4112 / 5112 / 6812

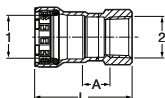

Part No.			Size (in)			A (in)		L (in)	
304 FKM	316 EPDM	316 FKM	1	2	Dec	Frac	Dec	Frac	
95260	90260	91240	½ x ½		0.67	1⅞	2.31	2⅞	
95265	90265	91245	¾ x ¾		0.68	1⅞	2.43	2⅞	
95270	90270	91250	1 x 1		0.71	1⅞	2.76	2¾	
95835	90885	91255	1¼ x 1¼		0.73	¾	3.27	3¼	
95275	90275	91260	1½ x 1½		0.73	¾	3.22	3¼	
95280	90280	91265	2 x 2		0.73	¾	3.44	3⅞	

MegaPress Stainless Adapter P x FPT – Models 4112XL / 5112XL / 6812XL

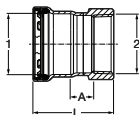

Part No.			Size (in)		A (in)		L (in)	
304 FKM	316 EPDM	316 FKM	1	2	Dec	Frac	Dec	Frac
95770	90740	98315	2½ x 2½		1.13	1⅛	3.86	3⅞
95775	90745	98320	3 x 3		1.17	1⅙	4.49	4½
95780	90750	98325	4 x 4		1.15	2⅛	5.42	5⅞

MegaPress Coupling with Stop, Stainless Steel, P x P – Models 4115 / 5115 / 6815

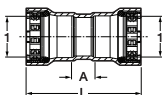

Part No.			Size (in)		A (in)		L (in)	
304 FKM	316 EPDM	316 FKM	1	Dec	Frac	Dec	Frac	
95285	90285	91100	½	0.56	9/16	2.78	2¾	
95290	90290	91105	¾	0.62	5/8	3.01	3	
95295	90295	91110	1	0.60	5/8	3.39	3⅝	
95800	90850	91115	1¼	0.70	11/16	4.42	4⅞	
95300	90300	91120	1½	0.89	7/8	4.71	4⅞	
95305	90305	91125	2	0.80	13/16	4.82	4⅞	

MegaPress Stainless Coupling with Stop P x P – Models 4115XL / 5115XL / 6815XL

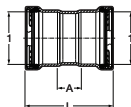

Part No.			Size (in)		A (in)		L (in)	
304 FKM	316 EPDM	316 FKM	1	Dec	Frac	Dec	Frac	
95645	90645	98375	2½	1.32	15/16	4.92	4⅞	
95650	90650	98380	3	1.38	1⅝	5.98	6	
95655	90655	98385	4	1.57	1⅞	7.87	7⅞	

MegaPress Coupling No Stop, Stainless Steel, P x P – Models 4115.5 / 5115.5 / 6815.5

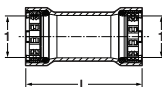

Part No.			Size (in)		L (in)	
304 FKM	316 EPDM	316 FKM	1	Dec	Frac	Frac
95310	90310	91290	½	2.78	2¾	
95315	90315	91295	¾	3.01	3	
95320	90320	91300	1	3.37	3⅝	
95805	90855	91305	1¼	4.42	4⅞	
95325	90325	91310	1½	4.71	4⅞	
95330	90330	91315	2	4.82	4⅞	

MegaPress Stainless Coupling No Stop P x P – Models 4115.5XL / 5115.5XL / 6815.5XL

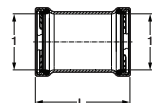

Part No.			Size (in)		L (in)	
304 FKM	316 EPDM	316 FKM	1	Dec	Frac	Frac
95660	90660	98360	2½	4.92	4⅞	
95665	90665	98365	3	5.98	6	
95670	90670	98370	4	7.91	7⅞	

MegaPress Reducer, Stainless Steel, P x P – Models 4115.2 / 5115.2 / 6815.2

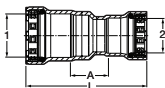

Part No.			Size (in)		A (in)		L (in)	
304 FKM	316 EPDM	316 FKM	1	2	Dec	Frac	Dec	Frac
95335	90335	91270	¾ x ½		1.14	1⅛	3.45	3⅙
95340	90340	91275	1 x ¾		1.18	1⅜	3.76	3¾
95820	90870	91280	1¼ x 1		1.19	1⅜	4.43	4⅙
95345	90345	91920	1½ x 1		1.28	1¼	5.05	5⅙
95350	90350	91285	2 x 1½		1.39	1⅜	5.31	5⅙

MegaPress Reducer, Stainless Steel, FTG x P – Models 4115.1 / 5115.1 / 6815.1

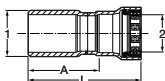

Part No.			Size (in)		A (in)		L (in)	
304 FKM	316 EPDM	316 FKM	1	2	Dec	Frac	Dec	Frac
95355	90355	91130	¾ x ½		1.85	1⅞	2.96	2⅝
95360	90360	91135	1 x ½		2.13	2⅞	3.24	3¼
95365	90365	91140	1 x ¾		2.03	2⅞	3.22	3¼
NA	NA	91320	1¼ x ¾		2.80	2⅓	4.00	4
95810	90860	91145	1¼ x 1		2.64	2⅝	4.02	4
95370	90370	91160	1½ x ¾		2.95	2⅝	4.15	4⅞
95375	90375	91150	1½ x 1		2.80	2⅓	4.19	4⅞
95815	90865	91155	1½ x 1¼		2.66	2⅞	4.52	4½
95380	90380	91165	2 x 1		3.11	3⅞	4.50	4½
NA	NA	91325	2 x 1¼		3.00	3	4.85	4⅞
95385	90385	91170	2 x 1½		2.94	2⅝	4.85	4⅞

MegaPress Stainless Reducer FTG x P – Models 4115.1XL / 5115.1XL / 6815.1XL

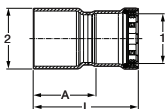

Part No.			Size (in)		A (in)		L (in)	
304 FKM	316 EPDM	316 FKM	1	2	Dec	Frac	Dec	Frac
95675	90675	98330	2 x 2½		2.97	3	4.96	4⅝
95680	90680	98335	2 x 3		3.76	3¾	5.75	5¾
95685	90685	98340	2½ x 3		3.75	3¾	5.55	5⅞
95690	90690	98345	2 x 4		5.28	5¼	7.27	7¼
95695	90695	98350	2½ x 4		5.27	5¼	7.06	7⅙
95700	90700	98355	3 x 4		5.03	5⅙	7.33	7⅞

MegaPress Union, Stainless Steel, P x P – Models 4160 / 5160 / 6860

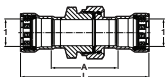

Part No.			Size (in)		A (in)		L (in)	
304 FKM	316 EPDM	316 FKM	1	2	Dec	Frac	Dec	Frac
95415	90415	91925	½		2.31	2⅝	4.53	4½
95420	90420	91930	¾		2.59	2⅞	4.98	5
95425	90425	91935	1		2.60	2⅞	5.37	5⅝
95875	90925	91940	1¼		2.76	2¾	6.48	6½
95430	90430	91945	1½		2.89	2⅞	6.71	6⅞
95435	90435	91950	2		3.61	3⅞	7.63	7⅞

MegaPress Flange, Stainless Steel, P x BP – Models 4159/5159/6859

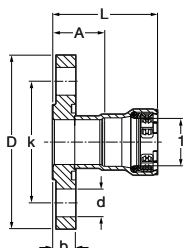

Part No.			Size (in)		A (in)		L (in)		b (in)		k (in)		D (in)		d (in)		
304 FKM	316 EPDM	316 FKM	1	Dec	Frac	Dec	Frac	Dec	Frac	Dec	Frac	Dec	Frac	Dec	Frac	Dec	Frac
95440	90440	91175	½	1.05	1 1/16	2.16	1 3/16	0.46	7/16	2.36	2 3/8	3.54	3 3/16	0.63	5/8		
95445	90445	91180	¾	1.19	1 3/16	2.39	2 3/8	0.53	½	2.76	2 ¾	3.94	3 15/16	0.63	5/8		
95450	90450	91185	1	1.30	1 3/16	2.68	2 11/16	0.58	9/16	3.11	3 1/8	4.33	4 3/8	0.63	5/8		
95870	90920	91190	1 ¼	1.39	1 3/8	3.24	3 ¼	0.64	5/8	3.50	3 ½	4.53	4 ½	0.63	5/8		
95455	90455	91195	1 ½	1.45	1 7/16	3.36	3 3/8	0.70	1/16	3.86	3 7/8	4.92	4 15/16	0.63	5/8		
95460	90460	91200	2	1.48	1 ½	3.49	3 ½	0.77	¾	4.76	4 ¾	5.91	5 15/16	0.75	¾		

MegaPress Stainless 2½" to 4" Adapter Flange P – Models 4159XL / 5159XL / 6859XL

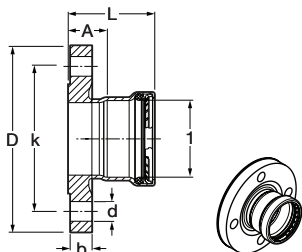

Part No.			Size (in)		A (in)		L (in)		b (in)		k (in)		D (in)		d (in)		
304 FKM	316 EPDM	316 FKM	1	Dec	Frac	Dec	Frac	Dec	Frac	Dec	Frac	Dec	Frac	Dec	Frac	Dec	Frac
95720	90720	98525	2 ½	1.54	1 9/16	3.33	3 5/16	0.89	7/8	5.51	5 ½	7.09	7 1/16	0.75	¾		
95725	90725	98530	3	1.65	1 9/16	3.95	3 15/16	0.96	15/16	5.98	6	7.48	7 ½	0.75	¾		

MegaPress Stainless 2½" to 4" Adapter Flange P – Models 4159XL / 5159XL / 6859XL

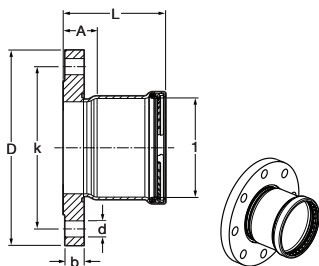

Part No.			Size (in)	A (in)		L (in)		b (in)		k (in)		D (in)		d (in)	
304 FKM	316 EPDM	316 FKM	1	Dec	Frac	Dec	Frac	Dec	Frac	Dec	Frac	Dec	Frac	Dec	Frac
95730	90730	98535	4	1.63	1½	4.80	4 ¹³ / ₁₆	0.96	¹⁵ / ₁₆	7.52	7½	9.06	9 ¹ / ₁₆	0.75	³ / ₄

MegaPress Cap, Stainless Steel, P x Cap – Models 4156 / 5156 / 6856

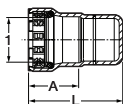

Part No.			Size (in)	A (in)		L (in)	
304 FKM	316 EPDM	316 FKM	1	Dec	Frac	Dec	Frac
95390	90390	91815	½	1.07	1 ¹ / ₁₆	2.14	2 ¹ / ₈
95395	90395	91820	³ / ₄	1.16	1 ³ / ₁₆	2.26	2 ¹ / ₄
95400	90400	91825	1	1.35	1 ³ / ₈	2.43	2 ⁷ / ₁₆
95825	90875	91830	1¼	1.86	1 ⁷ / ₈	2.93	2 ¹⁵ / ₁₆
95405	90405	91835	1½	1.87	1 ⁷ / ₈	3.02	3
95410	90410	91840	2	1.99	2	3.11	3 ¹ / ₈

MegaPress Stainless Cap P – Models 4156.1XL / 5156.1XL / 6856.1XL

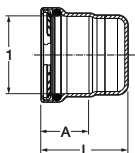

Part No.			Size (in)	A (in)		L (in)	
304 FKM	316 EPDM	316 FKM	1	Dec	Frac	Dec	Frac
95705	90705	98540	2½	1.80	1 ¹³ / ₁₆	3.27	3¼
95710	90710	98545	3	2.30	2 ⁵ / ₁₆	3.82	3 ¹³ / ₁₆
95715	90715	98550	4	3.18	3 ³ / ₁₆	4.67	4 ¹¹ / ₁₆

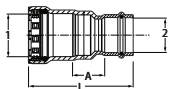
MegaPress to ProPress Transition Coupling, Stainless Steel, P x P – Models 4113 / 5113

Part No.		Size (in)		A (in)		L (in)	
304 FKM	316 EPDM	1 (IPS)	2 (CTS)	Dec	Frac	Dec	Frac
95465	90465	1/2	x 1/2	1.07	1 1/16	2.93	2 15/16
95470	90470	3/4	x 3/4	1.07	1 1/16	3.17	3 3/16
95475	90475	1	x 1	1.11	1 1/8	3.40	3 3/8
95840	90890	1 1/4	x 1 1/4	1.11	1 1/8	4.00	4
95485	90485	1 1/2	x 1 1/2	1.21	1 3/16	4.55	4 9/16
95490	90490	2	x 2	1.23	1 1/4	4.82	4 13/16

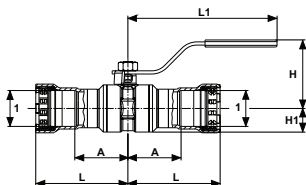
Viega MegaPress Stainless Ball Valve, P x P - Model 4170 / 4170XL / 5170 / 5170XL

Part No.		Size (in)	A (in)		L (in)		L1 (in)		H (in)		H1 (in)	
304 FKM	316 EPDM	1	Dec	Frac	Dec	Frac	Dec	Frac	Dec	Frac	Dec	Frac
29005	28975	1/2	1.54	1 9/16	2.62	2 5/8	4.57	4 9/16	1.99	2	0.63	5/8
29010	28980	3/4	1.64	1 5/8	2.80	2 13/16	4.57	4 9/16	2.10	2 1/8	0.75	3/4
29015	28985	1	1.81	1 13/16	3.16	3 3/16	5.77	5 3/4	2.47	2 1/2	0.88	7/8
29020	28990	1 1/4	1.98	2	3.80	3 13/16	5.77	5 3/4	2.71	2 11/16	1.14	1 1/8
29025	28995	1 1/2	2.14	2 1/8	4.01	4	6.12	6 1/8	3.02	3	1.36	1 3/8
29030	29000	2	2.38	2 3/8	4.37	4 3/8	6.12	6 1/8	3.32	3 5/16	1.66	1 11/16
86820	86805	2 1/2	3.72	3 3/4	5.52	5 1/2	11.09	11 1/16	5.14	5 1/8	2.26	2 1/4
86825	86810	3	4.09	4 1/16	6.40	6 3/8	11.09	11 1/16	5.54	5 9/16	2.66	2 11/16
86830	86815	4	4.64	4 5/8	7.84	7 13/16	13.06	13 1/16	6.70	6 11/16	3.35	3 3/8

MegaPress 3-Piece Ball Valve, Stainless Steel, P x P – Models 4175.8 / 4175.8XL / 5175.8 / 5175.8XL

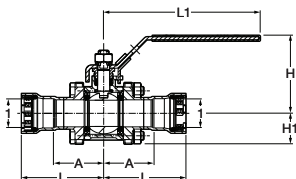

Part No.		Size (in)	A (in)		L (in)		L1 (in)		H (in)		H1 (in)	
304 FKM	316 EPDM	1	Dec	Frac	Dec	Frac	Dec	Frac	Dec	Frac	Dec	Frac
86500	86530	1/2	1.72	1 3/4	2.80	2 13/16	5.88	5 7/8	2.85	2 7/8	1.04	1 1/16
86505	86535	3/4	1.91	1 15/16	3.06	3 1/16	5.88	5 7/8	2.93	2 15/16	1.16	1 3/16
86510	86540	1	2.19	2 7/16	3.54	3 9/16	7.54	7 9/16	3.33	3 5/16	1.40	1 3/8
86515	86545	1 1/4	2.50	2 1/2	4.31	4 5/16	7.54	7 9/16	3.57	3 9/16	1.57	1 9/16
86520	86550	1 1/2	2.92	2 15/16	4.79	4 13/16	7.54	7 9/16	3.89	3 7/8	1.83	1 13/16
86525	86555	2	3.09	3 1/16	5.07	5 1/16	7.54	7 9/16	3.89	3 7/8	1.83	1 13/16
86650	86665	2 1/2	3.74	3 3/4	5.54	5 9/16	11.06	11 1/16	5.08	5 1/16	2.28	2 1/4
86655	86670	3	4.37	4 3/8	6.67	6 11/16	11.06	11 1/16	5.47	5 1/2	2.68	2 11/16
86660	86675	4	4.88	4 7/8	8.06	8 1/16	13.07	13 1/16	6.89	6 7/8	3.79	3 13/16

Sizes up to 3" have 4-bolt flanges; 4" has 6-bolt flanges.

Viega MegaPress 316 Check Valve, P x P - Model 5174

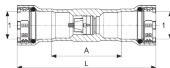

Part No.	Size (in)	A (in)		L (in)	
		1	Dec	Dec	Frac
29050	1/2	2.24	2 1/4	4.49	4 1/2
29055	3/4	2.32	2 5/16	4.69	4 11/16
29060	1	2.72	2 3/4	5.47	5 1/2
29065	1 1/4	2.99	3	6.73	6 3/4
29070	1 1/2	3.35	3 3/8	7.17	7 3/16
29075	2	3.94	3 15/16	7.95	7 5/16

Q What is Smart Connect technology?

A Smart Connect technology provides a quick and easy way to identify unpressed connections during the pressure-testing process. Unpressed connections are located by pressurizing the system with air or water. When testing with water, the pressure range is 15 psi to 85 psi maximum. When testing with air, the pressure range is ½ psi to 45 psi maximum. The flow path is removed during the pressing process, creating a leakproof, reliable connection. Guaranteed.

Q Why is Smart Connect technology so valuable?

A Smart Connect technology gives the user strong peace of mind. It allows for faster testing procedures since you do not have to shut down and drain the system. Costly damages and possible insurance claims and premiums can be avoided because it identifies unpressed connections before they can become a problem. Because of the time savings, projects stay on track.

Q Do I need additional equipment to install Viega MegaPress Stainless systems?

A No. Viega designed Viega MegaPress Stainless fittings to be compatible with the same jaws and press tools that are used for the Viega MegaPress carbon steel systems.

Q If a leak is discovered, is it necessary to drain the system prior to pressing the connection?

A No. It is not necessary to drain the system when making a repair.

Q How would an inspector know they are looking at a good connection?

A Good connections can be proven by performing a pressure test, using the same procedure for a fitting system.

Q What is the lubrication used on the sealing elements?

A The sealing elements are lubricated with a USDA approved H1 lubricant, meeting the requirement of FDA 21CFR. If it is necessary to lubricate the seals in the field, use water only. Do not use petroleum-based lubricants. Petroleum and EPDM are incompatible.

Q How long will the EPDM seal last?

A When properly installed, the EPDM seal and connection will last as long as the piping system.

Q How do I fabricate a system in tight places when using Viega MegaPress?

A If necessary, prefabricate connections that are in tight places and then install.

Q What is the warranty for Viega MegaPress Stainless fittings?

A Viega MegaPress stainless fittings carry a two-year warranty against defects in material and workmanship from Viega.

Q How do Viega MegaPress stainless connections hold up to freezing temperatures?

A Precautions should be taken for any piping system to protect the system from below-freezing temperatures.

Q What level of turbulence occurs in Viega MegaPress Stainless fittings, and will it cause premature wear in the piping?

A The long radius of Viega MegaPress elbows reduces turbulence typically experienced with traditional short-radius fittings. Not reaming the ID of the pipe is the largest contributing factor to turbulence and premature wear of any piping system.

Viega Metal Systems for Industrial Applications

Industrial applications are defined as non-residential and non-commercial applications not normally accessible to the general public, including manufacturing, mining, process or fabrication environments.

Subject to the terms and conditions of this Limited Warranty, Viega LLC (Viega) warrants to end users, installers, and distribution houses that its Viega metal press products (Viega Product) when properly installed in industrial applications shall be free from failure caused by manufacturing defects for a period of two (2) years from date of installation.

Under this Limited Warranty, you only have a right to a remedy if the failure or leak resulted from a manufacturing defect in the Viega Product and the failure or leak occurs during the warranty period. You do not have a remedy under this warranty and the warranty remedy does not apply if the failure or any resulting damage is caused by (1) components other than those sold by Viega; (2) not designing, installing, inspecting, testing, or maintaining the Viega Product in accordance with Viega's installation and product instructions in effect at the time of installation and other specifications and approvals applicable to the installation; (3) improper handling and protection of the Viega Product prior to, during, and after installation; inadequate freeze protection; or exposure to environmental or operating conditions not recommended for the application; or (4) acts of nature, such as, but not limited to, earthquakes, fire, flood, lightning, or weather damage. Final approval as to use compatibility to a specific process or fluid application is the responsibility of the engineer of record or responsible design/facilities personnel, and this Limited Warranty only applies to manufacturing defects in the Viega Product.

In the event of a leak or other failure in the Viega Product covered by this warranty, it is the responsibility of the end user to take appropriate measures to diminish any damage, to include making timely repairs. Only if the warranty applies will Viega be responsible for the remedy under this warranty. The part or parts which you claim failed should be kept and Viega contacted by writing to the address on the back page or telephoning 1-800-976-9819 within thirty (30)

calendar days after the leak or other failure and identifying yourself as having a warranty claim. You should be prepared to ship, at your expense, the product which you claim failed due to a manufacturing defect; and document the date of installation and the amount of the repair or replacement if performed by you. Within a reasonable time after receiving the product, Viega will investigate the reasons for the failure, which includes the right to inspect the product at a Viega location and reasonable access to the site of damage. Viega will notify you in writing as to the results of its review.

In the event that Viega determines that the failure or leak was the result of a manufacturing defect in the Viega Product covered by this warranty and to which this warranty applies, the EXCLUSIVE AND ONLY REMEDY under this warranty shall be the reimbursement for reasonable charges for repair or replacement of the Viega Product itself. VIEGA SHALL NOT BE LIABLE FOR CONSEQUENTIAL OR OTHER DAMAGE (FOR EXAMPLE, ECONOMIC LOSS OR WATER, PROPERTY, OR MOLD REMEDIATION) UNDER ANY LEGAL THEORY AND WHETHER ASSERTED BY DIRECT ACTION, FOR CONTRIBUTION OR INDEMNITY OR OTHERWISE.

THE ABOVE WARRANTY IS IN LIEU OF ALL OTHER WARRANTIES, EXPRESS OR IMPLIED, INCLUDING, BUT NOT LIMITED TO, THE IMPLIED WARRANTIES OR ANY STATUTE OF LIMITATIONS RELATING TO SUCH WARRANTIES. Other than this Limited Warranty, Viega does not authorize any person or firm to create for it any other obligation or liability in connection with its products.

This Limited Warranty gives you specific legal rights, and you also may have other rights, which may vary from state to state. This warranty shall be interpreted and applied under the law of the state in which the product is installed and is intended as a Commercial Warranty.

Viega Marine Applications

Marine applications are defined as mobile structures used to navigate water or stationary structures in water

Subject to the terms and conditions of this Limited Warranty, Viega LLC (Viega) warrants to end users, installers, and distribution houses that its Viega metal press products (Viega Product), when properly installed in approved marine applications, and other products sold by Viega LLC, when properly installed in marine applications in accordance with our listings, shall be free from failure caused by manufacturing defects for a period of two (2) years from date of installation. This warranty applies only to approved applications. Installations that are not approved shall not be covered by this warranty and shall not be the responsibility of Viega LLC.

Under this Limited Warranty, you only have a right to a remedy if the failure or leak resulted from a manufacturing defect in the Viega Product and the failure or leak occurs during the warranty period. You do not have a remedy under this warranty and the warranty remedy does not apply if the failure or any resulting damage is caused by (1) components other than those sold by Viega; (2) not designing, installing, inspecting, testing, or maintaining the Viega Product in accordance with Viega's installation and product instructions in effect at the time of installation and other specifications and approvals applicable to the installation; (3) improper handling and protection of the Viega Product prior to, during, and after installation; inadequate freeze protection; or exposure to environmental or operating conditions not recommended for the application; or (4) acts of nature, such as, but not limited to, earthquakes, fire, or weather damage. Final approval as to use compatibility to a specific process or fluid application is the responsibility of the engineer of record or responsible design/facilities personnel, and this Limited Warranty only applies to manufacturing defects in the Viega Product.

In the event of a leak or other failure in the Viega Product covered by this warranty, it is the responsibility of the end user to take appropriate measures to diminish any damage, to include making timely repairs. Only if the warranty applies will Viega be responsible for the remedy under this

warranty. The part or parts which you claim failed should be kept and Viega contacted by writing to the address on the back page or telephoning 1-800-976-9819 within thirty (30) calendar days after the leak or other failure and identifying yourself as having a warranty claim. You should be prepared to ship, at your expense, the product which you claim failed due to a manufacturing defect; and document the date of installation and the amount of the repair or replacement if performed by you. Within a reasonable time after receiving the product, Viega will investigate the reasons for the failure, which includes the right to inspect the product at a Viega location and reasonable access to the site of damage. Viega will notify you in writing as to the results of its review.

In the event that Viega determines that the failure or leak was the result of a manufacturing defect in the Viega Product covered by this warranty and to which this warranty applies, the EXCLUSIVE AND ONLY REMEDY under this warranty shall be the reimbursement for reasonable charges for repair or replacement of the Viega Product itself. VIEGA SHALL NOT BE LIABLE FOR CONSEQUENTIAL OR OTHER DAMAGE (FOR EXAMPLE, ECONOMIC LOSS OR WATER, PROPERTY, OR MOLD REMEDIATION) UNDER ANY LEGAL THEORY AND WHETHER ASSERTED BY DIRECT ACTION, FOR CONTRIBUTION OR INDEMNITY OR OTHERWISE.

THE ABOVE WARRANTY IS IN LIEU OF ALL OTHER WARRANTIES, EXPRESS OR IMPLIED, INCLUDING, BUT NOT LIMITED TO, THE IMPLIED WARRANTIES OR ANY STATUTE OF LIMITATIONS RELATING TO SUCH WARRANTIES. Other than this Limited Warranty, Viega does not authorize any person or firm to create for it any other obligation or liability in connection with its products.

This Limited Warranty gives you specific legal rights, and you also may have other rights, which may vary from state to state. This warranty shall be interpreted and applied under the law of the state in which the product is installed and is intended as a Commercial Warranty.



Viega LLC

585 Interlocken Blvd.
Broomfield, CO 80021

Ph: 800-976-9819
Fax: 800-976-9817
www.viega.us

