

**Instructions for Use**

**MegaPress® Press-In Branch Connector Tool Kit**



**US**

**Model**    **Model Year**  
4878.5    03/2016

07/2023





Viega products are designed to be installed by licensed and trained plumbing and mechanical professionals who are familiar with Viega products and their installation. **Installation by non-professionals may void Viega LLC's warranty.**



This document is subject to updates. For the most current Viega technical literature please visit [www.viega.us](http://www.viega.us).

# TABLE OF CONTENTS

<b>1</b>	<b>About this Document</b> .....	<b>4</b>
1.1	Target Groups.....	4
1.2	Symbols Used.....	4
<b>2</b>	<b>Product Information</b> .....	<b>5</b>
2.1	Intended Use.....	5
2.1.1	Areas of Use.....	5
2.2	Product Description .....	7
2.2.1	Press-In Branch Connector.....	7
2.2.2	Tool Set .....	7
2.3	Compatible Pipes.....	11
2.3.1	Component Marking .....	13
2.4	Accessories and Spare Parts .....	14
<b>3</b>	<b>Handling</b> .....	<b>16</b>
3.1	Safety Advice .....	16
3.2	Assembly Information .....	17
3.2.1	Space Requirements and Distances.....	17
3.2.2	Required Tools .....	21
3.3	Assembly.....	23
3.3.1	Preparing Pipes.....	23
3.3.2	Creating the Drill Hole .....	25
3.3.3	Mounting Press-In Branch Connector with Press-In Tool.....	34
3.3.4	Additional Use of Press-In Branch Connector .....	40
3.4	Commissioning .....	41
3.4.1	Leak Test.....	41
3.5	Care and Maintenance .....	42
3.5.1	Cleaning .....	42
3.5.2	Maintenance Intervals .....	43
3.5.3	Replacing the Hole Saw .....	44
3.5.4	Replacing Pilot Bit.....	46
3.5.5	Replacing Mount for Drilling Machine.....	47
3.6	Disposal .....	49
<b>4</b>	<b>Viega MegaPress Limited Warranty</b> .....	<b>50</b>

US

# 1 About this Document

## 1.1 Target Groups

The information in this manual is directed at HVAC and plumbing professionals as well as other trained specialists.

The installation of Viega products must take place in accordance with engineering best practices and these Viega Instructions for Use.

Individuals without the above mentioned training or qualification to mount, install, and maintain, if required, are not permitted to service this product. This restriction does not extend to possible operating instructions.

These Instructions for Use must be kept together with the tool set.

## 1.2 Symbols Used

Warning and advisory texts are set apart from the remainder of the text and are labeled with the relevant symbols.



**DANGER!**  
**Danger to life and other hazards!**

This symbol warns against possible fatal injuries.



**WARNING!**  
**Risk of injury!**

This symbol warns against possible serious injuries.



**CAUTION!**  
**Risk of injury!**

This symbol warns against possible injuries.



**NOTICE**

This symbol warns against possible damage to property.



This type of note provides additional tips.

## 2 Product Information

### 2.1 Intended Use



The use of the MegaPress tool set and the MegaPress Press-In Branch Connector for other areas of use and other media than those described herein must be approved by Viega Technical Services.

#### 2.1.1 Areas of Use

The MegaPress Press-In Branch Connector is designed for schedule 10 and schedule 40 steel pipes. The Press-In Branch Connector creates a threaded connection in the steel pipes. It is particularly suitable where space is at a premium, e.g., in pipe manifold installation for sensors, thermometers, or drains.

The Press-In Branch Connector is not suitable for use in drinking water installations.

The Press-In Branch Connector may not be used for fuel gases according to ANSI LC4 or in combination with ProPress® stainless steel components.

Use is possible in the following areas:

- Industrial systems
- Compressed air systems
- Shipbuilding
- Heating and cooling systems (closed loop)
- Systems for technical gases (on request)
- Other applications pending Viega approval

US

### EPDM Model Numbers

Area of Use	Heating	Compressed Air	Technical Gases
Operating temperature [T <sub>max</sub> ]	250°F	140°F	—
Operating pressure [P <sub>max</sub> ]	200 psi	200 psi	—
Comments	—	Dry, oil content: < 25 mg / m3	<sup>1</sup>

<sup>1</sup> Consultation with Viega Technical Services required.

### FKM Model Numbers

Area of Use	Heating	Compressed Air	Technical Gases
Operating temperature [T <sub>max</sub> ]	284°F	140°F	—
Operating pressure [P <sub>max</sub> ]	200 psi	200 psi	—
Comments	—	Dry, oil content: > 25 mg / m3	<sup>1</sup>

<sup>1</sup> Consultation with Viega Technical Services required.

### Compressed Air Systems

In compressed air systems, the following operating pressures may not be exceeded:

Pipe Dimension (Inches)	Operating Pressure P <sub>max</sub>
1½, 2, 2½, 3, 4	200 psi
6	145 psi

## 2.2 Product Description

Various components and tools are required to create a press-in branch connection.

### 2.2.1 Press-In Branch Connector

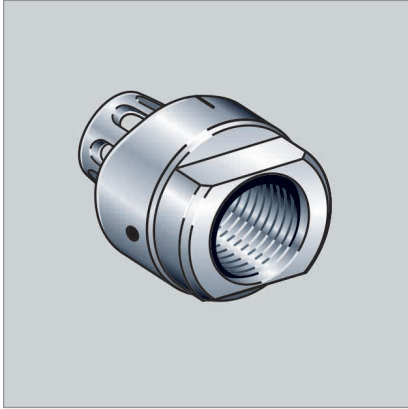

A separate Press-In Branch Connector is available for the different pipe dimensions. The Press-In Branch Connector is fitted with a sealing element made of EPDM or FKM.



The sealing element may not be replaced.

The Press-In Branch Connector has an external zinc nickel coating and it is suitable for schedule 10 and schedule 40 steel pipes according to ASTM A53, see 2.3 “Compatible Pipes” on Page 11. The Press-In Branch Connector is available with a  $\frac{3}{4}$ " internal NPT thread in accordance with ASME B1.20.1.

US

### 2.2.2 Tool Set



The tool set (part number 26920) for the Press-In Branch Connector is available in a case.

- 1 - Positioning aids (D 1½-4, 6 inch)
- 2 - Press-in tool
- 3 - Installer swage for press-in tool
- 4 - Drilling shaft
- 5 - Drilling device for guiding drilling shaft
- 6 - Instructions for use
- 7 - Marking pen

## Drilling Device with Tension Chain for Guiding Drilling Shaft

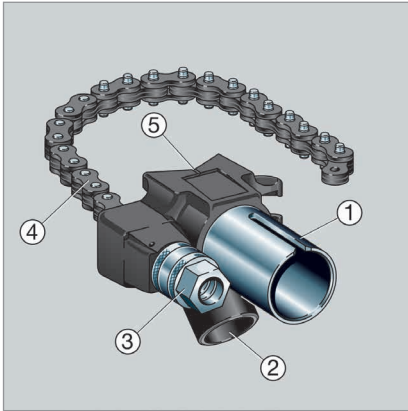

- 1 - Guide for drilling shaft
- 2 - Vacuum cleaner connection 1¼".
- 3 - Tension nut
- 4 - Tension chain
- 5 - Milled recess as marking for subsequent alignment

## Drilling Shaft

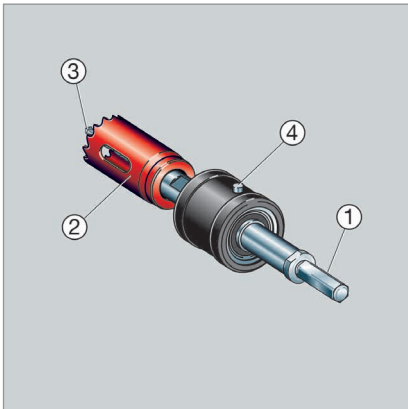

- 1 - Drilling shaft with hexagonal drive
- 2 - 1½" hole saw
- 3 - Pilot bit
- 4 - Guide bolt

Alternatively, the hexagonal drive can be replaced by an SDS plus mount. We recommend that you use the hexagonal drive here.



## Press-In Tool

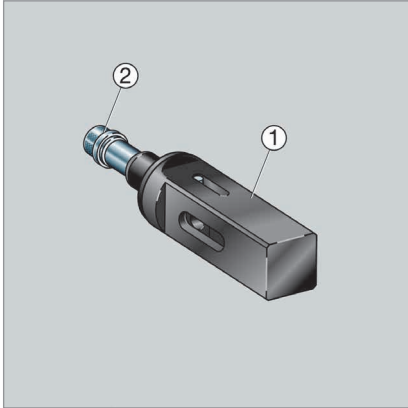

- 1 - Insert for press machine
- 2 - Installer swage

US

### Positioning Aid D 1½-2½" and D 3", 4", and 6"

The positioning aids are to be used for mounting the individual Press-In Branch Connectors. A separate positioning aid is available for each pipe dimension.

The nominal outer diameter is specified on the positioning aid in both inches and millimeters.

#### Positioning Aid D 1½-2½"

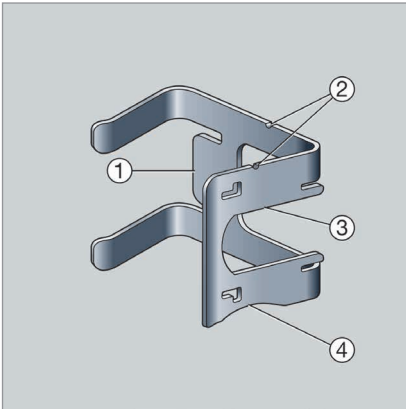

- 1 - Handle
- 2 - Markings help to mark out additional Press-In Branch Connectors around the circumference of the pipe
- 3 - Recess for key surface on Press-In Branch Connector
- 4 - Pipe template - the correct pipe dimension can be checked using the positioning aid

#### Positioning Aid D 3", 4", and 6"

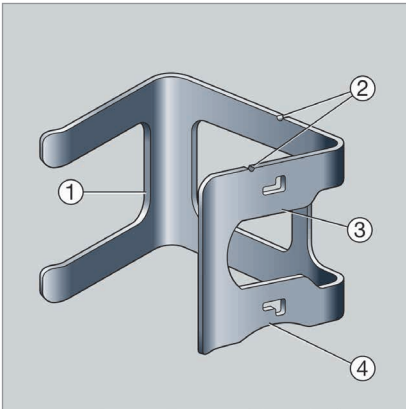

- 1 - Handle
- 2 - Markings help to mark out additional Press-In Branch Connectors around the circumference of the pipe
- 3 - Recess for key surface on Press-In Branch Connector
- 4 - Pipe template - the correct pipe dimension can be checked using the positioning aid

## 2.3 Compatible Pipes



The information in this chapter is not applicable to sprinkler systems, see “Compressed Air Systems” on Page 6.

The Press-In Branch Connector can be used with the following seamless steel pipes or steel pipes welded along the longitudinal seam:

- Black
- Galvanized
- Industrially painted
- Powder coated

The steel pipes must comply with the following standard:

- All pipe in accordance with ASTM A53

To ensure proper operation, the correct Press-In Branch Connector for the given pipe dimension and correct schedule of pipe must be used. If this requirement is not met, leaks and malfunctions may occur.



Observe the specified tolerances for the pipe wall thickness.

**US**

### ASTM A53 and ASME B 36.10

ASTM A53 and ASME B 36.10 differentiate between schedules and set tolerances for standard steel pipe. The table below is a summary of acceptable dimensions.

For Pipe Dimension	Nominal External Diameter	External Diameter		Wall thickness for Schedule 10	Wall thickness for Schedule 40
		Min. Inches	Max. Inches		
1½	1.900	1.884	1.916	0.109	0.145
2	2.375	2.359	2.391	0.109	0.154
2½	2.875	2.859	2.891	0.120	0.203
3	3.500	3.484	3.516	0.120	0.216
4	4.500	4.484	4.516	0.120	0.237
6	6.625	6.609	6.641	0.134	0.280

## 2.3.1 Component Marking

### Press-In Branch Connector

The Press-In Branch Connectors are marked with a green dot for EPDM sealing elements and a white dot for FKM sealing elements. This identifies Smart Connect® technology, which provides the installer quick and easy identification of an unpressed fitting during a leak test. When the fitting is pressed, a secure, non-detachable, mechanical connection is created. Smart Connect technology provides the installer with an easy way to see connections that have not been pressed before putting the system into operation.

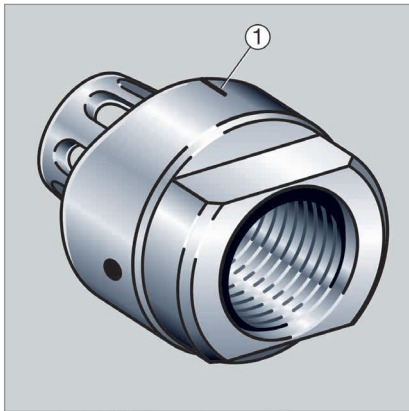

A marking has been made on the Press-In Branch Connector (1). This is used to check that the marking line and Press-In Branch Connector mark line up with each other.

The nominal outside diameter is specified on the Press-In Branch Connector in inches and millimeters. Branch connectors are also marked with schedule of pipe they are intended to be used with (schedule 10 or schedule 40). Additionally, branch connectors with an FKM sealing element have the additional “FKM” marking on them.

US

## 2.4 Accessories and Spare Parts

Various matching accessories and spare parts are available for the tool set:

### Hole Saw

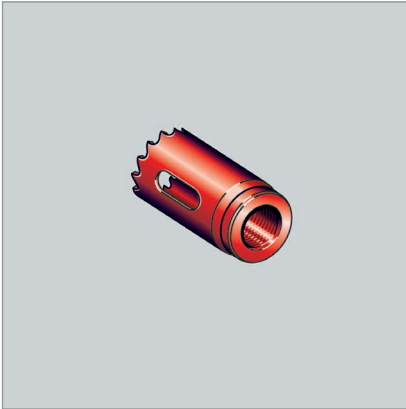

The hole saw's outside diameter is  $1\frac{1}{16}$ ".

We recommend that you use the following spare hole saws (outside diameter  $1\frac{1}{16}$ "):

- Equivalent RIDGID article

Worn hole saws may not be used, as by doing so the drill hole will not be circular or it may be too small, which in turn means that the Press-In Branch Connector can no longer be fitted into place.



Hole saws and the drilling device are matched to each other. If other hole saws are used, the leak tightness can no longer be assured.

## Pilot Bit

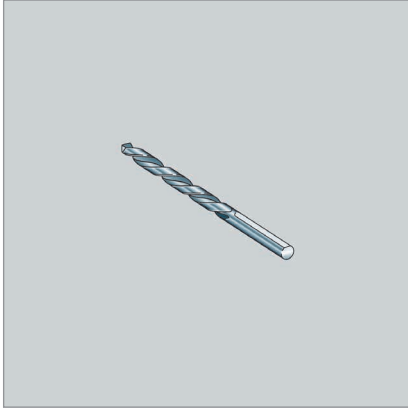

The pilot bit has a diameter of  $\frac{1}{4}$ " , a length of  $3\frac{3}{4}$ " and it is flattened at the mounting surface. This flattening off helps to fasten the pilot bit firmly in place.

We recommend that you use the Viega pilot bit. Alternatively, HSS drills according to ANSI/ASME B94.1 1M-1993 with flattened off mounting surface may be used.

## SDS-Plus Drill Mount

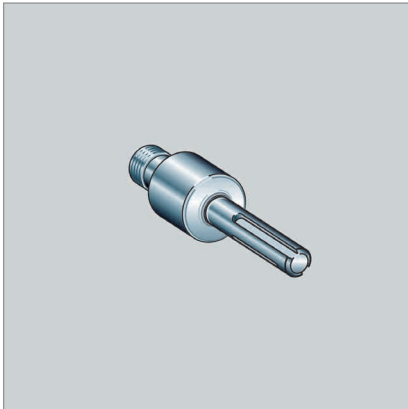

If you are using a drill equipped with an SDS-plus drill chuck, an SDS-plus mount is available for purchase instead of using the hexagonal drive adapter.

US

## 3 Handling

### 3.1 Safety Advice



The applicable accident-prevention regulations are relevant for all work conducted.  
Safety goggles and suitable hand protectors must be used.

#### Mandatory Labels

Note the mandatory labels and warning signs affixed to the drill guide:



General warning signs



Follow instructions for use



Wear head protection



Wear eye protection

#### Transport and Storage

- To protect the tools against damage or loss, always transport them in the designated cases only.
- Make sure case and tools are dry and clean before storage.

#### Safety When Drilling

- Before using the tool, always check that it operates properly and smoothly.
- Do not use damaged components. Use undamaged original system parts only.



- Tools or individual components may be damaged if dropped. Drill machines that have been dropped may not be used. They must be replaced or sent to a service provider for inspection.
- Before drilling, completely drain the pipelines and depressurize them.
- Note minimum distances specified for the tools, see 3.2.1 “Space Requirements and Distances” on Page 17.
- Filings are created when drilling. Always wear suitable safety goggles.
- The hole saw, pilot bit, and coupon can get very hot. Allow parts to cool down after drilling is finished. Use suitable hand protectors to dismantle the parts. Do not place hot parts onto combustible materials.
- Follow the safety instructions in the drill machine and suction device manual.

## Maintenance

- Follow maintenance, repair, and care instructions.
- All maintenance and repair work is to be conducted by Viega-authorized service companies only.

US

## 3.2 Assembly Information

### 3.2.1 Space Requirements and Distances



#### **CAUTION!**

#### **Risk of injury due to insufficient distances.**

If, when mounting the Press-In Branch Connector, the necessary minimum distances are not met, personal injuries and damage to other components may occur.

After mounting the Press-In Branch Connector, the Branch Connector must not have any thermal loads applied to it, e.g., through welding work that has higher temperatures than the approved maximum permissible operating temperature. If the pipeline is to be bent at a later stage, the Press-In Branch Connector may not be located in the bend area. Maintain a minimum distance of 0.5 x pipe outside diameter to the bend area.

We recommend that you always check the space requirements before drilling. Connectors, clamps, etc., may not be installed in the area of the bore hole. Keep a distance of 2" so that you can properly mount the positioning and drilling device.

Minimum distances are available in the table on the next page.

### Minimum Distances for Drill Machine, Press Machine, and Positioning Aid

The working area **A** is dependent on the drill machine used.

Area **A** is made up of the length of the drill machine plus the length of the drilling shaft (6.69").

Working area **B** is the length of the press machine (including 0.79" working travel) with the Press-In Tool and Press-In Branch Connector.

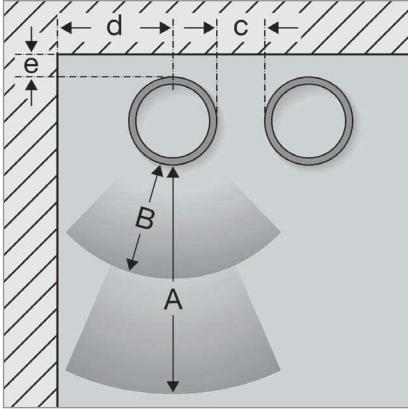

Press Machine	Working Area B
RIDGID CT 400	20.5"
RIDGID RP 320-E	16.5"
RIDGID RP 330-B/C	17.3"
RIDGID RP 340	15.5"

The minimum distances c, d, and e must be complied with for mounting the drilling device and the positioning aid.

Dimension in Inches	Minimum Distance c in Inches	Minimum Distance d in Inches	Minimum Distance e in Inches
1 ½	1.18	4.33	1.18
2	1.18	4.33	1.18
2 ½	1.18	4.33	1.18
3	1.38	4.33	1.38
4	1.57	4.33	1.57
6	2.17	5.71	2.17

### Minimum Distances Between Press-In Branch Connectors Lengthwise to the Pipe Axis

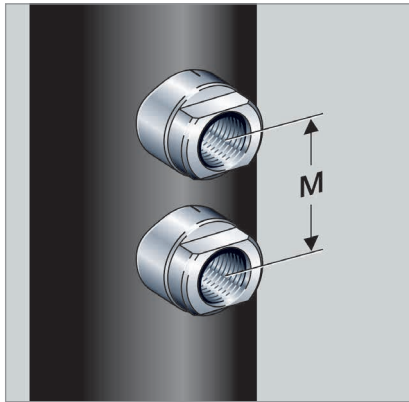

Dimension in Inches	M in Inches
1½	2.76
2	
2½	
3	
4	
6	

US

### Minimum Distances Between Press-In Branch Connectors Perpendicular to the Pipe Axis

If Press-In Branch Connectors are to be mounted close to each other, minimum distances must be maintained to ensure that the positioning aid can be used correctly.

Care must be taken to ensure that all the holes are drilled first and then the Press-In Branch Connectors mounted, as otherwise the tension chain cannot be properly fitted into place.

**i** The specified minimum distances must be maintained to ensure that the Press-In Branch Connectors can be properly mounted. If, e.g., thermometers are used, other minimum distances may be required. This must be checked in advance.

The minimum distance N relates to the angle of the Press-In Branch Connectors to each other. It is indicated in degrees in the table.

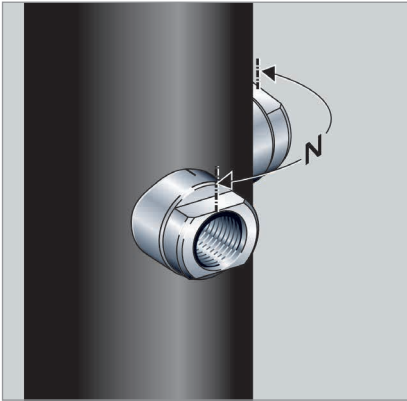

Dimension in Inches	N	Symbol
1½	180°	
2		
2½		
3	90°	
4		
6		

### 3.2.2 Required Tools

The following tools are required for making the press-in branch connection:

- Drill machine/hammer drill
- Press machine
- Suction device, e.g., shop vacuum
- Marking pen
- 27 mm metric or adjustable wrench
- 32 mm metric or adjustable wrench
- Screwdriver
- Wire brush
- Sandpaper (180 grit)
- Where applicable, pipe gripper

US

#### Drill Machine or Hammer Drill

Commercially available drill machines or hammer drills can be used for the drilling shaft. We recommend the use of high-performance machines. When using a cordless drill, the drilling period lasts significantly longer.

Drill machines or hammer drills will be known from here onward as drill machines.

Drill machines must meet the following specifications at least:

- Power consumption:  $\geq 600$  watt
- Maximum drilling speed: 1200 rpm
- Drill chuck: SDS-plus or hexagonal drive
- Impact hammer function: The machine must be able to switch off the hammer impact function
- Torque limiter: Machine must be equipped with a torque limiter



**The hammer impact function must be switched off.**

Use properly operating, true-running drill machines only.

The correct speed is a very important factor for the service life of the hole saw.

## Press Machine

When mounting the MegaPress Press-In Branch Connector, we recommend that you use RIDGID press tools.

Recommended RIDGID press tools:

- RP 340
- RP 330-B or C
- RP 320-E
- CT 400

Unsuitable press machines:

- RP 200-B
- RP 210-B
- RP 240
- PEX-one

## Suction Device

Filings are created when drilling.

Connecting a suction device to the drill machine enables the entry of any filings into the pipeline to be kept to a minimum.

The pipelines must be depressurized and fully drained to prevent any residual volumes from also being sucked in.



### **Caution!** **Risk of Fire!**

Hot filings can cause damage to the suction device or immediate surroundings. The suction device must not be equipped with any combustible parts such as a dust bag. The manufacturer's specifications must always be observed.

To enable the filings to be suctioned off, the following specifications for the suction device must be met:

- Type: Industrial vacuum cleaner
- Power consumption:  $\geq 1200$  watt or 10 amps
- Air volume:  $\geq 105$  CFM
- Vacuum:  $\geq 80$  inches of water column
- Connection fitting size: 1¼"
- Commercially available adapters to 1¼" can be used for other connection sizes.

### 3.3 Assembly

#### General Information on Linear Expansion of Pipelines

Pipelines expand due to differences in temperature. If the Press-In Branch Connector is to be used for a drain pipeline, care should be taken when selecting the hole position to ensure that the linear expansion of the drain and through pipelines only generates minor tensions on the Press-In Branch Connector. The maximum permissible linear expansion for the through pipeline is  $\pm 0.39$ ".

If larger linear expansions cannot be ruled out, then use the appropriate expansion joints as well as fixed and floating points in accordance with the best practices of engineering.

US

#### 3.3.1 Preparing Pipes

##### Requirements on Profile Seal Contact Surface

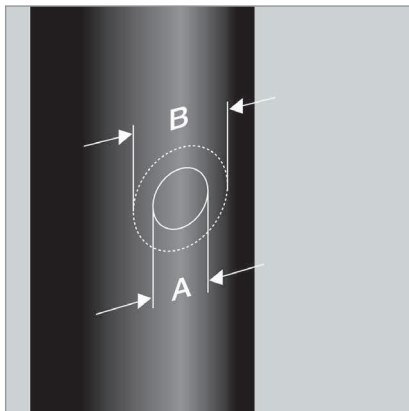

- The mounting surface of the Press-In Branch Connector is at least 1.97" (B).
- The drill hole is located in the center of the mounting surface.
- The drill hole diameter is 1<sup>1</sup>/<sub>16</sub>" (A).

## Reasons for Uneven Pipe Surface

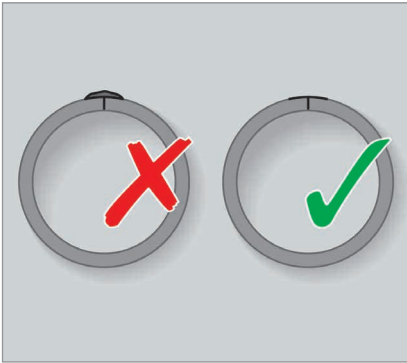

A significant degree of unevenness on the pipe surface may lead to a leak in the Press-In Branch Connector.

An uneven pipe surface can be caused by:

- Poorly smoothed-out pipe weld seams
- Manually applied paint
- For galvanized pipes: bumps in the zinc coating

Where possible, the Press-In Branch Connector should not be positioned on weld seams. If this cannot be avoided, the weld seam is to be matched to the pipe bend. Do not press into recesses in the weld seam.

## Pipe Surface Requirements for Press-In Branch Connector Installation

- Pipe surfaces must be smooth, free of indentations (even and undamaged), pits, and deformations, and must be clean and free of dirt, debris, rust, scale, oil, and grease. It is not necessary to completely remove protective coatings or to expose the bare steel material.
- To avoid leak paths, do not place the Press-In Branch Connector over engraved, embossed, or stamped pipe. Engraving or stamping shall not be removed through use of a grinder or other tool
- The pipe surface does not exhibit any unevenness. In the event of any unevenness, the sealing surface area for the Press-In Branch Connector must be machined so that a smooth and level surface is created. We recommend that you remove any contamination in advance, e.g., apply a wire brush to any scales first and then smooth down the surface using sand cloth or sandpaper (180 grit).
- For drilling, the pipe must have a minimum wall thickness, see 2.3 “Compatible Pipes” on Page 11.
- The pipe wall in the area of the hole must not be damaged or weakened (e.g., through internal or external corrosion).
- Connectors, clamps, etc., may not be installed in the area of the hole. The drilling device must be able to be properly mounted.
- Paint, coatings, or shellac applied to pipe must be smooth or removed prior to installation.



### 3.3.2 Creating the Drill Hole



#### **CAUTION!**

#### **Risk of Injury**

Risk of injury through metal filings and falling machines.

- Wear safety goggles.
- Wear safety shoes.

#### **Note on Filings**

Filings are created when drilling. Connecting a suction device to the drill machine enables the entry of any filings into the pipeline to be kept to a minimum.

#### **Note on Pilot Bit**

- A hole may not be drilled without using a pilot bit.
- Do not use a worn pilot bit.
- Do not regrind the pilot bit.

US

#### **Requirements**



It is important that the drill hole is properly drilled. This will ensure that the Press-In Branch Connector can be correctly installed so that it will operate smoothly.

Viega recommends the use of the tool set, part number 26920.

- If the drill hole is drilled without using the tool set (e.g., through an upright drilling machine) the perpendicular drill hole must have an outside diameter of  $1.06" \pm 0.03"$ .
- The pipe section must be depressurized and drained before drilling the hole.
- Read the following sections before drilling the hole:
  - 3.2.1 “Space Requirements and Distances” on Page 17 and
  - 3.3.1 “Preparing Pipes” on Page 23.

## Marking Drill Hole

Follow the mounting steps in the given sequence.

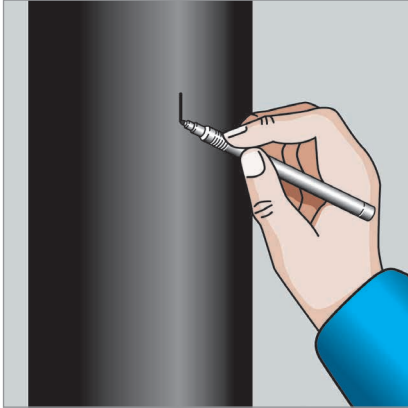

- ▶ Clean hole area before marking.
- ▶ Mark center of drill hole at required position.

- ▶ Making marking lines.  
Make the marking lines so that they are longer than the Press-In Branch Connector. This makes it easier to align later on.

There are markings on the drilling device and the Press-In Branch Connector. When mounted later on, the marking line on the pipe must line up with the markings.



If more Press-In Branch Connectors are to be mounted lengthwise to the pipe axis (between each other or next to each other), then the marking line must run above the first and last Press-In Branch Connector.

## Mounting Drilling Device

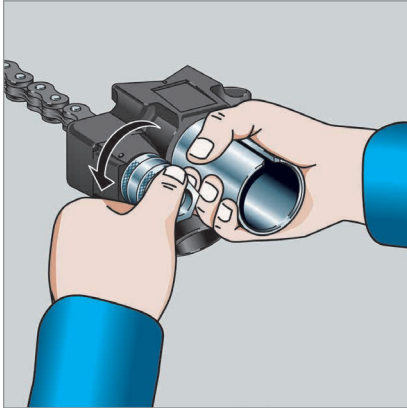

- ▶ Unscrew tension nut in counter-clockwise direction until fully open.

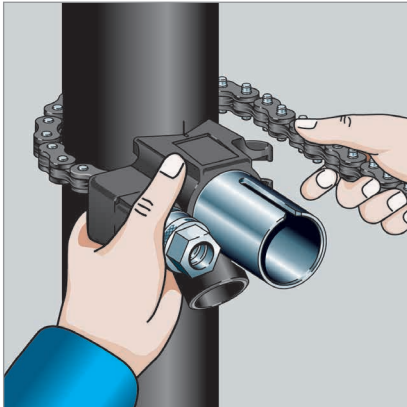

- ▶ Fit tension chain around pipe so that it makes contact all the way around.

Mount drilling device with vacuum hose connection facing downward.



For horizontal lines, the tension chain is to be routed over the top of the pipe.

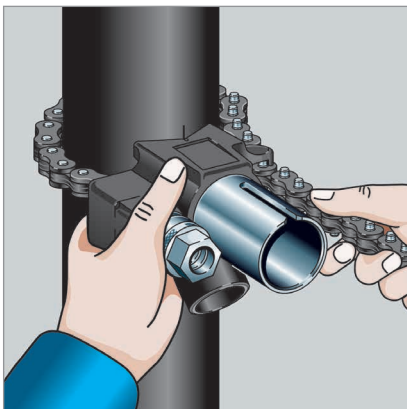

- ▶ Insert the bolts of the next nearest chain link into the drilling device's bolt mounting.



The bolts must be fully inserted into the bolt mounting. Otherwise, damage or an increased amount of wear may result.

US

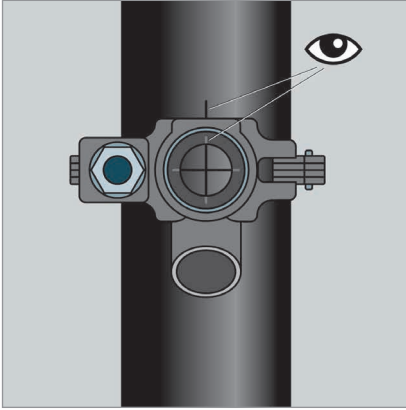

- ▶ Align the drilling device along each pipe axis.

To do so, line up the outer milled recess on the drilling device and the marking lines on the pipe.

- ▶ Align the drill hole center marked on the pipe with the aid of the markings on the inner milled recess.

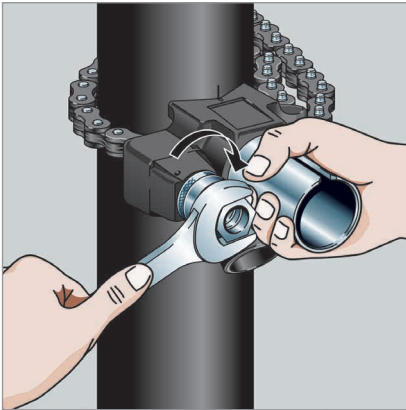

- ▶ Hand-tighten tension nut and ensure alignment.



Do not tighten tension chain too much or too little. This could lead to damage.

- ▶ Tighten tension nut using a 27 mm metric or adjustable wrench until it is firmly seated (maximum 7.37 ft.lbs).

## Preparing Tools

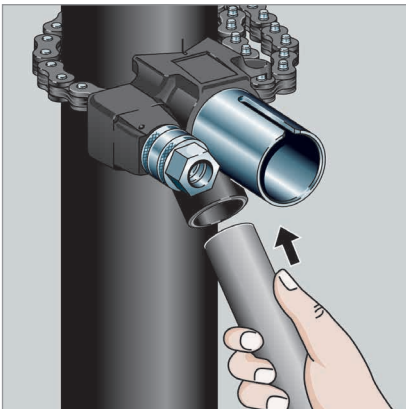

- ▶ Slide vacuum hose into hose connection on drilling device.

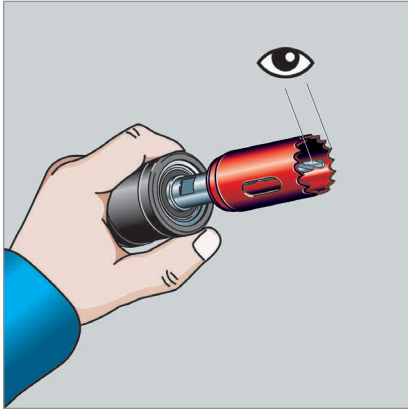

- ▶ Check the hole saw and pilot bit for damage, wear, and correct vertical clearance between the two (0.08"). Replace parts, if necessary.
- ▶ Check the pilot bit for firm seat; tighten if necessary.



Use undamaged parts only.

Do not use grease and oils (e.g., cutting oil) when drilling. Otherwise, the sealing element on the Press-In Branch Connector may be damaged.

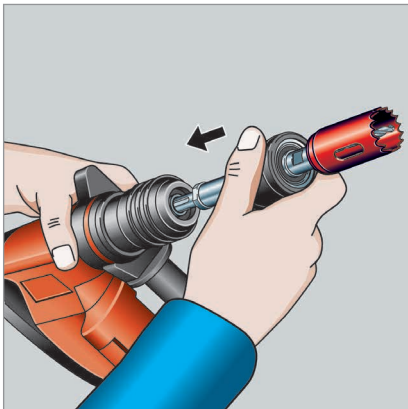

- ▶ Insert drilling shaft into drilling machine (SDS-plus) or clamp drilling shaft using hexagon adapter into chuck.

US



- ▶ Switch off hammer impact function.
- ▶ Set to clockwise rotation.

## Drilling Drill Hole

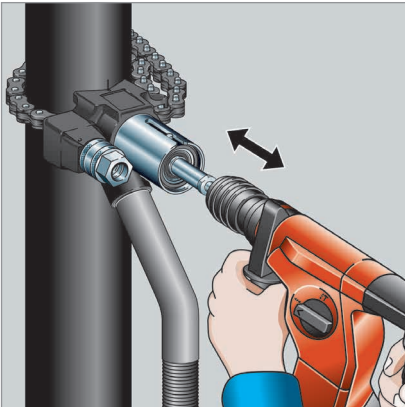
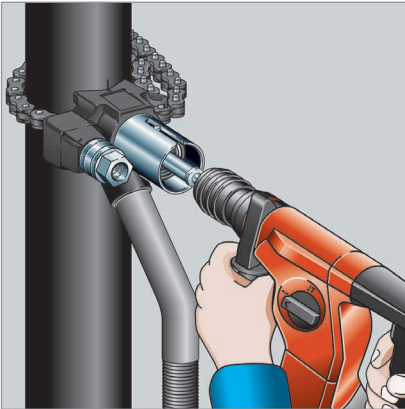
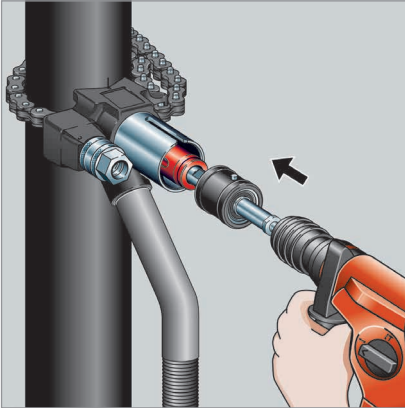

Do not switch on drilling machine yet!

- ▶ Slide guide bolt of drilling shaft into guide on drilling device.
- ▶ Apply slight pressure to push drilling shaft up to stop unit in drilling device.

While doing so, do not tilt the drilling shaft or the hole saw.

- ▶ Switch on suction device.
- ▶ Switch on drilling machine.
- ▶ Drill complete hole in a single operation.

Apply some pressure while doing so.



Since the filings will need to be removed during the drilling process, the following technique should be applied.

- ▶ When drilling, occasionally release pressure on the drill by backing off at regular intervals to allow filings to be extracted and keep the bit cool.

## Ending Drilling Procedure



### CAUTION!

Risk of injury and risk of igniting combustible materials through hot hole saw or pilot bit.

Allow time to cool down.

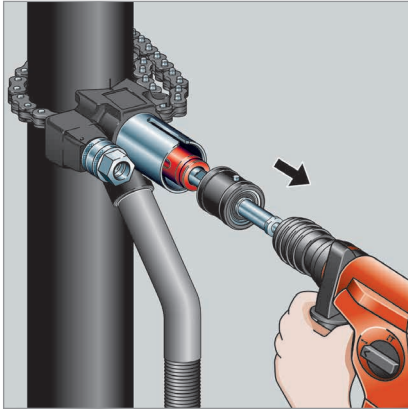

- ▶ Finish the drilling procedure once:
  - The pipe wall has been fully drilled through, or
  - The stop unit in the drilling device has been reached.
- ▶ Only remove drilling machine with drilling shaft after the drilling shaft has stopped turning.

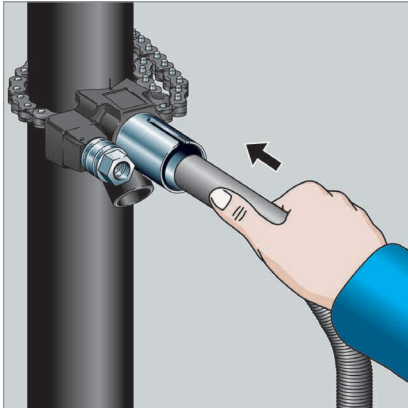

- ▶ Detach suction hose and use to clean out drill hole and debris inside pipe by inserting the hose into the drilling device shaft.
- ▶ Switch off suction device and place to one side.

US

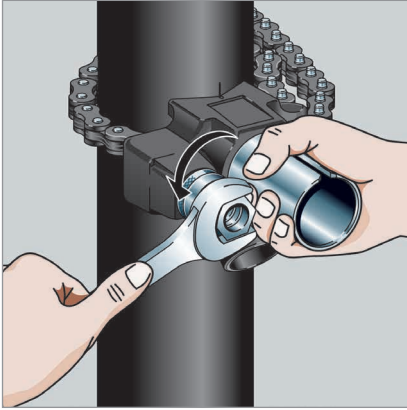

► Dismantle drilling device.

### Concluding Activities

The hole saw with the pilot bit has been designed such that — ideally — the coupon remains in the hole saw.

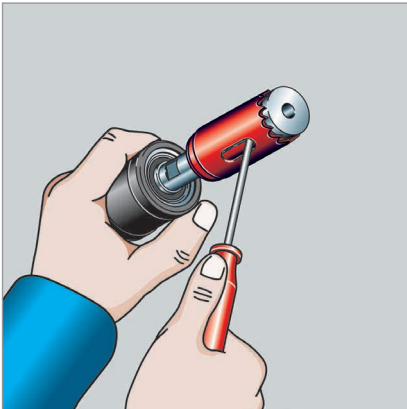

#### **CAUTION!**

Risk of injury through slipping off or hot coupon. Allow time to cool down.

► Remove coupon from the hole saw using a screwdriver and adjustable pliers.

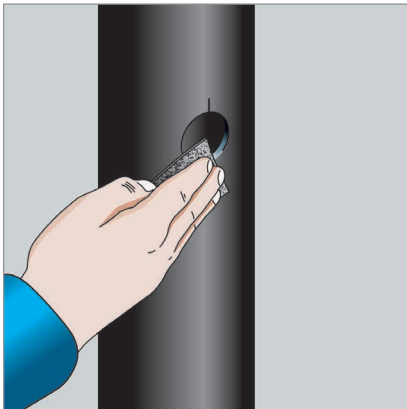
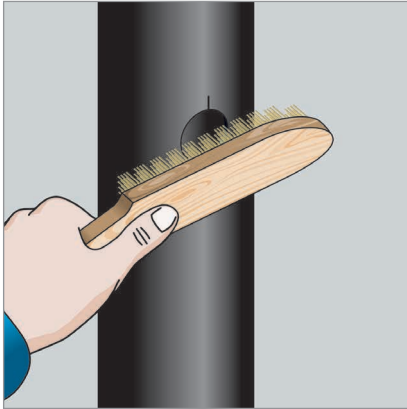

**CAUTION!**

Risk of injury! Do not reach into the drill hole.

- ▶ Use a wire brush to clean the pipe surface around the drill hole. A rotary brush can also be used.

- ▶ Break or round off any residual burrs using sandpaper or similar. The mounting surface for the sealing element should be smooth.

US



The drill hole may not be subsequently filed down. A protruding burr will mean that the Press-In Branch Connector cannot be inserted far enough into the pipe or that the sealing element may be damaged. Any leaked oil must be completely cleaned up.

- ▶ Remove any applied (cooling) lubricants.

### 3.3.3 Mounting Press-In Branch Connector with Press-In Tool

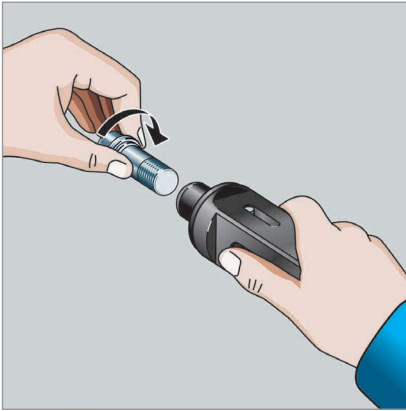

- ▶ Remove installer swage from press-in tool.

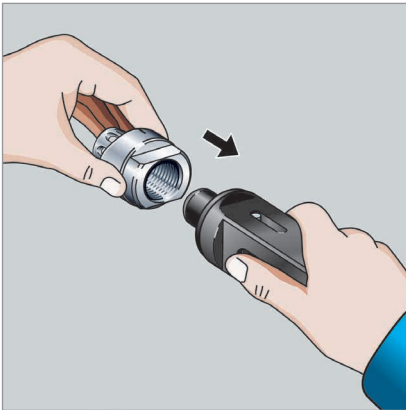

**i** Always select the matching Press-In Branch Connector for the given pipe dimension and pipe schedule. Note marking on Press-In Branch Connector!

- ▶ Fit Press-In Branch Connector onto Press-In Tool.  
The key surface must make contact with the Press-In Tool: The sealing element for the Press-In Branch Connector must face toward the pipe.

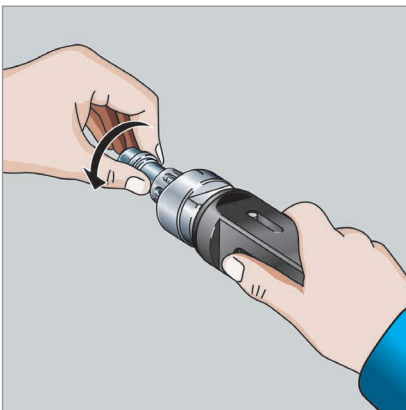

- ▶ Turn installer swage lightly until hand-tight.

**!** If this is not done, the installer drift may break off or the pressing procedure will not be conducted correctly.

- ▶ Check sealing element for correct seating, cleanliness, and intactness.

## Mounting Positioning Aid



### CAUTION!

#### Risk of crushing!

Grasp the positioning aid so that your fingers cannot get trapped!

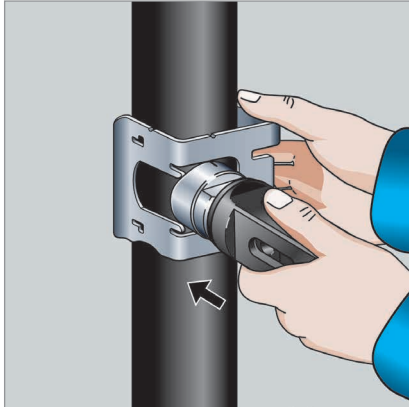

- ▶ Place positioning aid around the pipe.



If the Press-In Branch Connector is to be mounted on the side of the installation pipe, then the closed side of the positioning aid, in its installed position, should not face toward the wall to ensure that it cannot get jammed when being subsequently disassemble.

US

- ▶ Insert Press-In Branch Connector into the drill hole.

For purposes of orientation, line up the marking on the Press-In Branch Connector with the marking line on the pipe.



Always select the matching positioning aid and the matching Press-In Branch Connector for the given pipe dimension and pipe schedule. Note the sizes on the positioning aid and the Press-In Branch Connector!

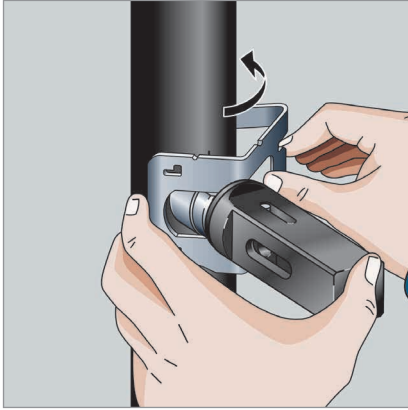

- ▶ Move the recess for the key surface by swivelling it toward the Press-In Branch Connector.



If the positioning aid cannot be mounted properly, you can rotate it 180°.

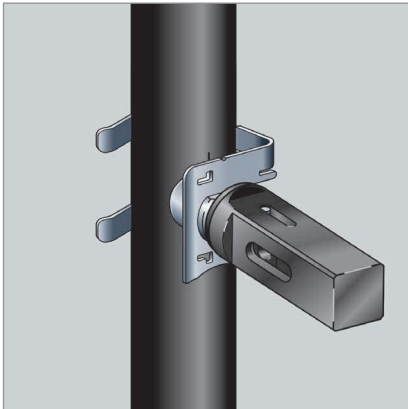

- ▶ Turn positioning aid far enough until it makes full contact with the Press-In Branch Connector and the pipe.

The following points must be met to ensure that the Press-In Branch Connector is in the correct position:

- The Press-In Branch Connector must make full contact with the pipe.
- The Press-In Branch Connector is located in the end position of the positioning aid's recess.
- The positioning marking for the Press-In Branch Connector and the marking line on the pipe line up. The positioning aid must make contact with the pipe here.

## Pressing-in Press-In Branch Connector

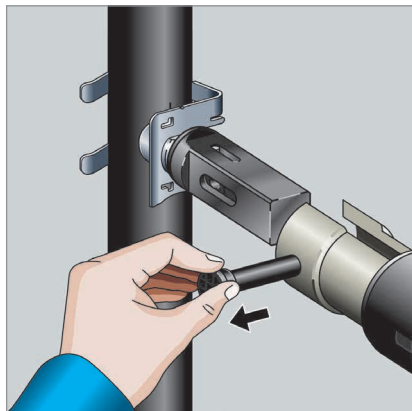

- ▶ Pull out press machine's retaining bolt.

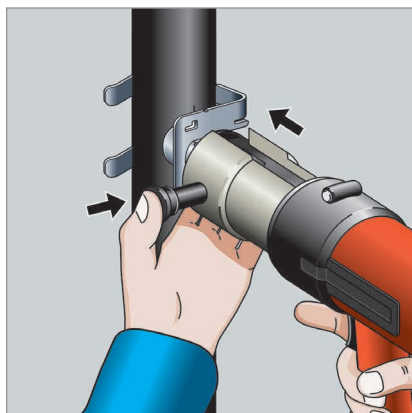

- ▶ Slide press machine all the way up onto the press-in tool.
- ▶ Slide in retaining bolt.



Both the Press-In Branch Connector and positioning aid must make full contact with the pipe wall.

US

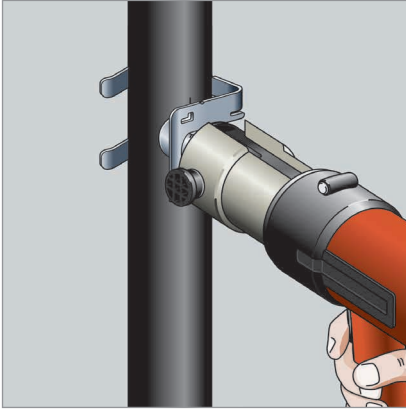

**CAUTION!**  
**Risk of crushing!**  
Hold press machine in handle area only.

**i** As the machine moves back by 0.79", it should not be fixed in place. Note section 3.2.1 "Space Requirements and Distances" on Page 17 should be observed.

- ▶ Switch on press machine.
- ▶ Hold press machine level and at right angles to pipe axes.  
Note the rebound action of the positioning aid here. This provides noticeable feedback as to whether the press machine is perpendicular to the pipe axes or not.

Do not leave the press machine suspended on the positioning aid.

- ▶ Pressing should be fully conducted in a single operation.

**!** Occasionally the machine may terminate the pressing process even though the press-in tool cannot be released yet. In this case, start a second pressing process.

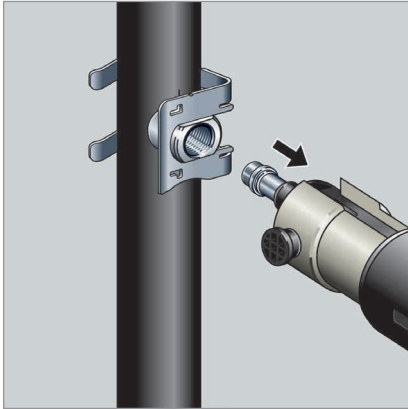

- ▶ Pull out press machine with Press-In Tool once pressing is finished.



**CAUTION!**

**Risk of crushing or tool breakage!**

Do not conduct any empty pressing without a Press-In Branch Connector. The Press-In Branch Connector may only be pressed into the pipe.

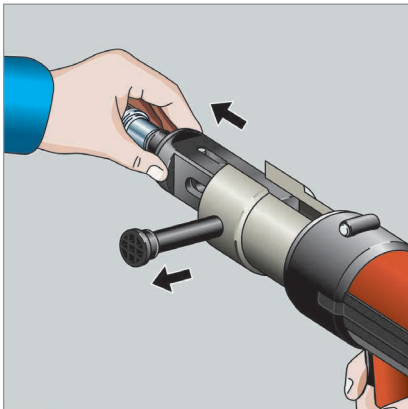

- ▶ Remove Press-In Tool from machine.

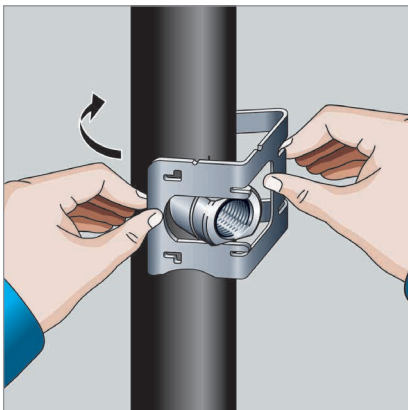

**CAUTION!**

**Risk of crushing!**

Grasp the positioning aid so that your fingers cannot get trapped!

- ▶ Remove positioning aid from pipe. Pull lightly on handle while doing so.

US



- ▷ The Press-In Branch Connector is properly mounted and it can now be used.



Alignment afterward is not permitted!

If you screw an external thread into the Press-In Branch Connector, you must counterhold the key surface using a suitable tool (e.g., 32 mm metric or adjustable wrench).

After completing the installation, perform a leak test, see 3.4.1 “Leak Test” on Page 41.

### 3.3.4 Additional Use of Press-In Branch Connector

The NPT thread can be used for the installation of thermometers, temperature sensors, manometers, or drains.

It is also possible to connect pipelines, e.g., for subsequent radiator connections.

We recommend that you use Viega piping systems for this.



If the connected pipeline has to be aligned again afterward, then only the pipeline may be aligned.

The Press-In Branch Connector may not have any temporary or permanent mechanical load applied to it during the alignment procedure.



## 3.4 Commissioning

### 3.4.1 Leak Test

The installer must perform a leak test (load and leak test) before commissioning.

The best practices of engineering must be observed.

The requirements for drinking water installations serve as the basis for the Authority Having Jurisdiction (AHJ) and its local codes and regulations must be complied with.

The leak test should also be conducted in non-drinking water installations in accordance with these regulations.

The result must be documented.



To prevent corrosion, the system must remain full of water after the leak test has been performed.

US

### Flushing System

After the leak test, the system is to be flushed in accordance with the acknowledged rules of engineering and in accordance with AHJ regulations.

## 3.5 Care and Maintenance

### 3.5.1 Cleaning

To ensure permanent and proper operation, the tool must be cleaned at regular intervals.

Cleaning agent:

- Clean cotton cloth
- Maintenance oil (WD 40)



Do not use silicone oil!

### Drilling Device Including Tension Chain

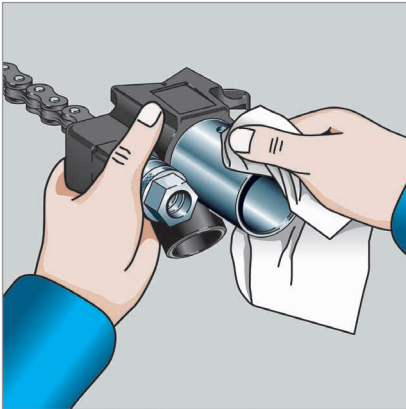

- Use cloth and maintenance oil to clean inside and outside of drilling device.

## Drilling Shaft Including Hole Saw

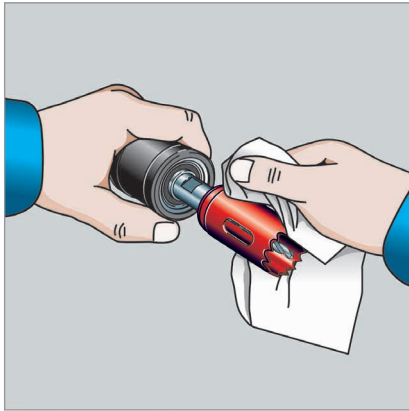

- ▶ Use cloth and maintenance oil to clean outside of bearing and hole saw.

### 3.5.2 Maintenance Intervals

US

Functional safety is primarily dependent on the operational safety of the individual tools. The tools are subject to wear and tear. This is why the tools must undergo regular maintenance.

#### Hole Saw and Pilot Bit

The hole saw and pilot bit must be replaced by the user as soon as any signs of wear appear. When properly used, the Viega components can reach the following number of drilled holes:

<b>Hole saw</b>	If mainly used on pipes with minimum wall thickness of 0.09"	Approx. 100 drilled holes
<b>Hole saw</b>	If mainly used on pipes with maximum wall thickness of 0.21"	Approx. 30 drilled holes
<b>Pilot bit</b>		Approx. 80 drilled holes

#### Drilling Device, Drilling Shaft, Press-In Tool



Maintenance and repair work on the tools may only be conducted by Viega-authorized service providers.

The components must be serviced every 2 years.

## Positioning Aid

The positioning aid is maintenance free. It has to be replaced if it no longer functions satisfactorily or if it is damaged.

### 3.5.3 Replacing the Hole Saw

The hole saw should be replaced when the following signs appear:

- If the drilling effect diminishes (e.g., if the applied force required when drilling increases)
- If teeth are damaged or badly worn.

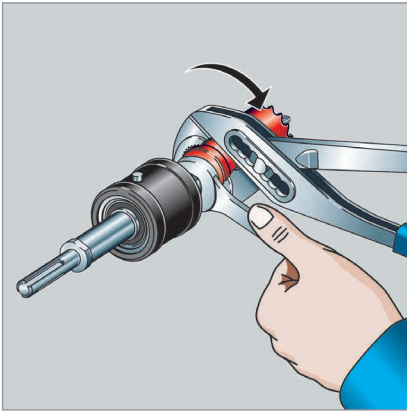

#### **CAUTION!**

Risk of injury through hot and sharp-edged hole saw.

- Wear suitable hand protectors if necessary.
- Allow hole saw to cool down first.

- ▶ Use pipe gripper to release and then detach hole saw from drilling shaft.

Counterhold using a 14 mm metric or adjustable wrench to ensure that the drilling shaft is not damaged.

- ▶ Remove hole saw.

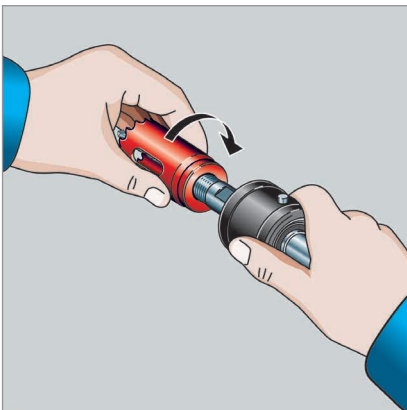

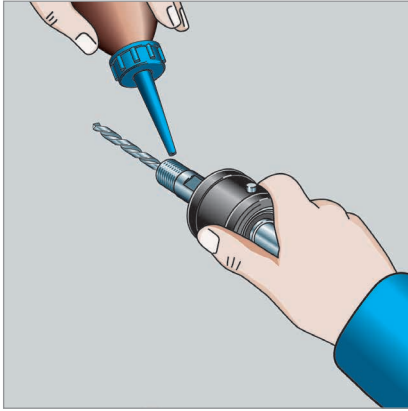

- ▶ Apply lubricant to drilling shaft's fine-pitch thread for every change. This makes it easier to release the drilling shaft later on.

It is acceptable to use lubricants that contain MoS<sub>2</sub> or graphite. If the thread is damaged, the drilling shaft or the hole saw may no longer be used.

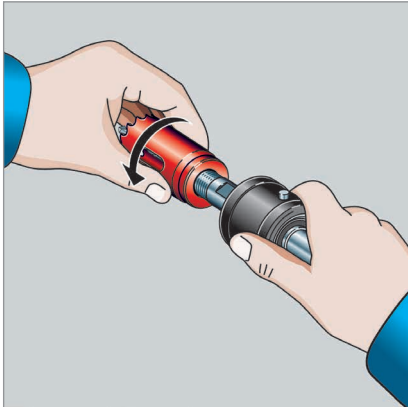

- ▶ Mount new hole saw and tighten by hand up to stop unit. Do not tilt hole saw when screwing it in.
- ▷ The hole saw will tighten independently during the next drilling procedure.

US

### 3.5.4 Replacing Pilot Bit

The pilot bit must be replaced as soon as any signs of wear appear.



**CAUTION!**

**Risk of injury through hot hole saw.**

- Wear suitable hand protectors if necessary.
- Allow hole saw to cool down first.

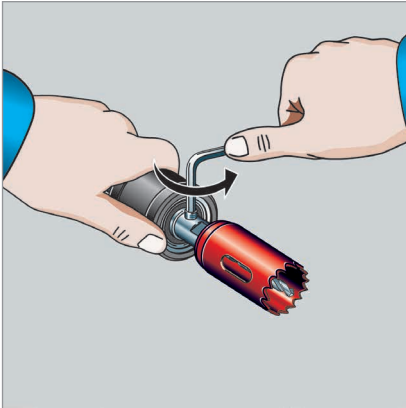

- ▶ Remove fixing screw of pilot bit using Allen key (4 mm).

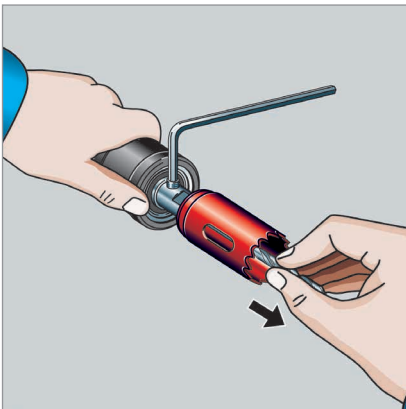

- ▶ Remove pilot bit.
- ▶ Slide new pilot bit far enough into drilling shaft so that it protrudes by  $\frac{1}{8}$ " out of the hole saw.  
Rotate pilot bit far enough around its axis so that the flattened area lines up exactly with the fixing screw.

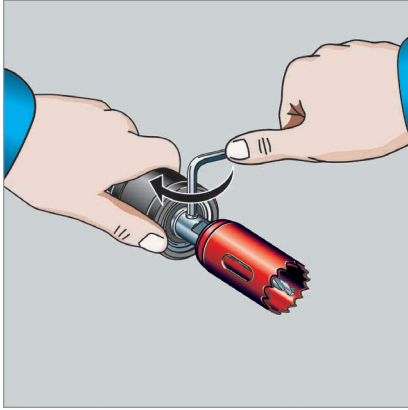

- ▶ Tighten fixing screw using Allen key to prevent the pilot bit from also turning during the drilling procedure.

### 3.5.5 Replacing Mount for Drilling Machine

The drilling shaft is equipped with a hexagonal drive. For drilling machines with an SDS-plus mount, the hexagonal drive can be replaced by an SDS-plus mount.

US

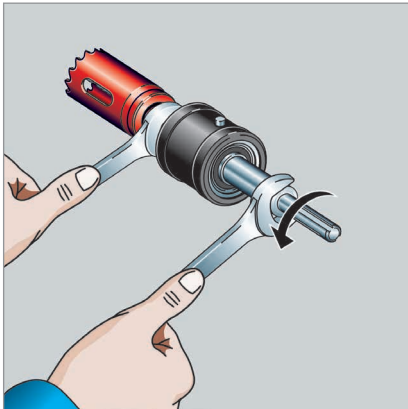

- ▶ Release adapter from drilling shaft using a 17 mm metric or adjustable wrench.  
Counterhold using a 14 mm metric or adjustable wrench to ensure that the drilling shaft is not damaged.

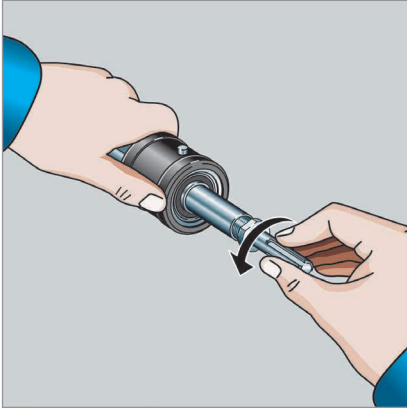

- ▶ Remove adapter.

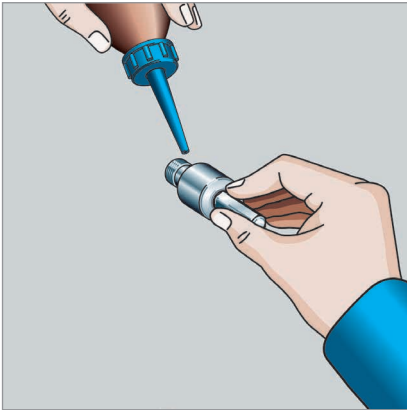

- ▶ Apply lubricant to adapter's fine-pitch thread for every change. This makes it easier to release the adapter later on.

It is acceptable to use lubricants that contain MoS2 or graphite. If the thread is damaged, the adapter may no longer be used.

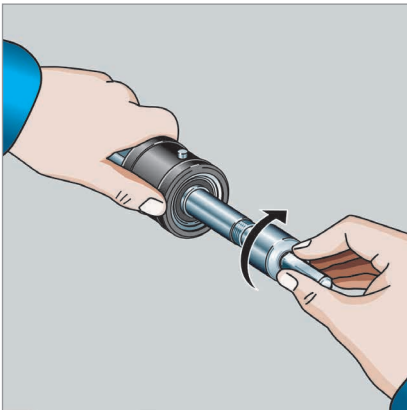

- ▶ Screw in adapter and tighten by hand up to stop unit. Do not tilt adapter when positioning or screwing the it in.
- ▷ The adapter will tighten independently during the next drilling procedure.



## 3.6 Disposal

Separate the product and packaging materials (i.e., paper, metal, plastic, or non-ferrous metals) and dispose in accordance with valid national legal requirements.

## 4 Viega MegaPress Limited Warranty

Subject to the conditions and limitations in this Limited Warranty, Viega LLC (Viega) warrants to end users, installers, and distribution houses that its Viega MegaPress metal press fittings including MegaPress, MegaPress FKM, MegaPress 304 FKM, MegaPress 316, and MegaPress 316 FKM (Viega Product) with application appropriate sealing element when properly installed in non-industrial and non-marine applications and under specified operating conditions of use shall be free from failure caused by manufacturing defects for a period of fifteen (15) years from date of installation. MegaPress valves, when properly installed and under normal conditions of use, will be free of failure from manufacturing defects for a period of two (2) years from date of installation.

Under this Limited Warranty, you only have a right to a remedy if the failure or leak resulted from a manufacturing defect in the Viega Product and the failure or leak occurs during the warranty period. You do not have a remedy under this warranty and the warranty remedy does not apply if the failure or any resulting damage is caused by (1) components other than those manufactured or sold by Viega, such as black iron pipe; (2) not designing, installing, inspecting, testing, or maintaining the Viega Product in accordance with Viega's installation and product instructions in effect at the time of installation and other specifications and approvals applicable to the installation; (3) use of Viega Product under non recommended system operating conditions, improper handling and protection of the Viega Product prior to, during and after installation, inadequate freeze protection, or exposure to environmental conditions not recommended for the application; or (4) acts of nature, such as, but not limited to, earthquakes, fire, or weather damage. In the event of a leak or other failure of the Viega Product covered by this warranty, it is the responsibility of the end user to take appropriate measures to mitigate any damage, to include making timely repairs. Only if the warranty applies will Viega be responsible for the remedy under this warranty. The part or parts which you claim failed should be kept and Viega contacted by writing to the address below or telephoning 1-800-976-9819 within thirty (30) calendar days after the leak or other failure and identifying yourself as having a warranty claim. You should be prepared to ship, at your expense, the product which you claim failed due to a manufacturing defect, document the date of installation, and the amount of the repair or replacement if performed by you. Within a

reasonable time after receiving the product, Viega will investigate the reasons for the failure, which includes the right to inspect the product at a Viega location and reasonable access to the site of damage. Viega will notify you in writing as to the results of its review.

In the event that Viega determines that the failure or leak was the result of a manufacturing defect in the Viega Product covered by this warranty and this warranty applies, the EXCLUSIVE AND ONLY REMEDY under this warranty shall be the reimbursement for reasonable charges for repair or replacement of the Viega Product itself. VIEGA SHALL NOT BE LIABLE FOR ANY CONSEQUENTIAL OR OTHER DAMAGE (FOR EXAMPLE, ECONOMIC LOSS, WATER OR PROPERTY OR MOLD REMEDIATION) UNDER ANY LEGAL THEORY AND WHETHER ASSERTED BY DIRECT ACTION, FOR CONTRIBUTION OR INDEMNITY OR OTHERWISE.

THE ABOVE WARRANTY IS IN LIEU OF ALL OTHER WARRANTIES, EXPRESS OR IMPLIED, INCLUDING, BUT NOT LIMITED TO, THE IMPLIED WARRANTIES OF MERCHANTABILITY AND FITNESS FOR A PARTICULAR PURPOSE OR ANY STATUTE OF LIMITATIONS RELATING TO SUCH WARRANTIES. Other than this Limited Warranty, Viega does not authorize any person or firm to create for it any other obligation or liability in connection with its products.

This Limited Warranty gives you specific legal rights and you also may have other rights which may vary from state to state. This warranty shall be interpreted and applied under the law of the state in which the product is installed and is intended as a COMMERCIAL WARRANTY.

US



**Viega LLC**

585 Interlocken Blvd.  
Broomfield, CO 80021

Phone (800) 976-9819  
[www.viega.us](http://www.viega.us)

IM-MP 599437 0723 MegaPress Branch Connector (EN)

