

Product Instructions

Viega MegaPress®G Ball Valves 2½" to 4"

EN Product Instructions Viega MegaPressG Ball Valves 2½" to 4"

This document is subject to updates. For the most current Viega technical literature please visit www.viega.us.



Viega LLC
585 Interlocken Blvd.
Broomfield, CO 80021

Phone (800) 976-9819
www.viega.us

PI-MP 530824 0622 MegaPressG Ball Valves 2½ to 4

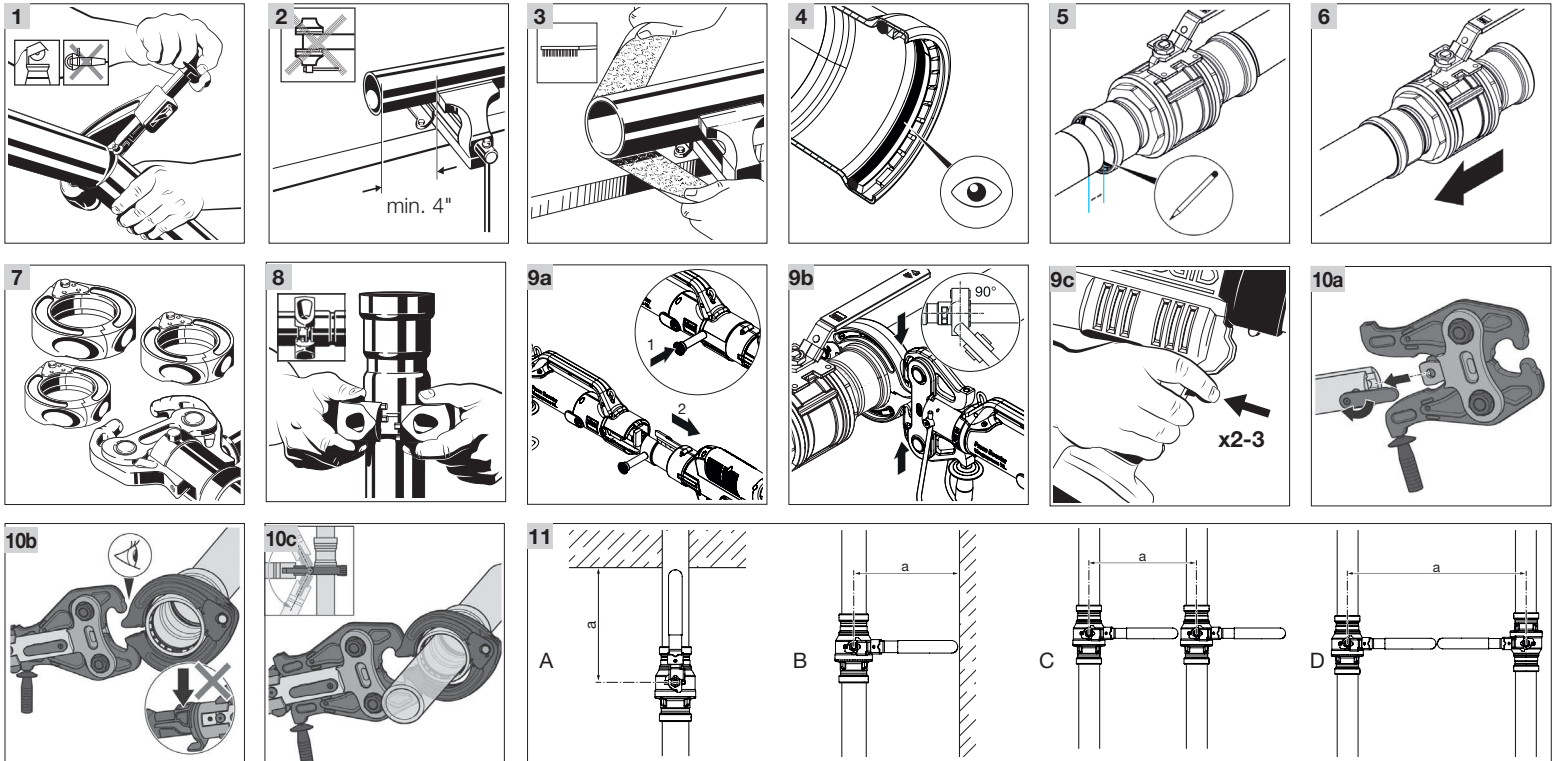

EN

Viega MegaPressG Ball Valves 2½" to 4"

! Viega products are designed to be installed by licensed and trained plumbing and mechanical professionals who are familiar with Viega products and their installation. **Installation by non-professionals may void Viega LLC's warranty.**

DANGER!
Read and understand all instructions for installing Viega MegaPressG valves. Failure to follow all instructions may result in extensive property damage, serious injury, or death.

Caution!
The valves are for use with fuel gases and are intended for the operating pressure 0-125 psi.

Caution!
The fuel gas system shall not be used as a grounding electrode for an electrical system.

i Viega recommends using pipe hangers with a distance of 6" to 8" in front of and behind the press connections or in accordance with local codes.

- 1 Cut pipe at right angles using displacement type cutter.
- 2 Keep end of pipe a minimum of 4" away from the contact area of the vise to prevent possible damage to the pipe in the press area.
- 3 Remove burr from inside and outside of the pipe and prep to proper insertion depth using a preparation tool or fine grit sandpaper.
- 4 Illustration demonstrates proper fit of grip ring, separation ring, and sealing element.

Caution!
Due to the brittle nature of the graphite separator ring, extra care must be taken when sliding the valve onto the pipe so as not to damage the separator ring.

- 5 Mark proper insertion depth. Improper insertion depth may result in an improper seal. It is recommended that the depth marking be visible on the completed assembly.

Insertion Depth (in)	d (in)
2½	1 ¹³ / ₁₆
3	2 ⁵ / ₁₆
4	3 ¹ / ₈

- 6 While turning slightly, slide valve onto the pipe to the marked depth. End of pipe must contact stop.
- 7 Viega MegaPress 2½" to 4" valve connections must be made using MegaPress XL rings and either the MegaPress XL PressBooster or the MegaPress Z3 actuator.

Warning!
! Keep extremities and foreign objects away from press tool during pressing operation to prevent injury or incomplete press.

- 8 Open MegaPress XL ring and place at right angles on the valve. The MegaPress XL ring must be engaged on the valve bead. Check insertion depth.

Pressing with MegaPress XL PressBooster

- 9a Remove the retaining bolt of the press machine. Slide the PressBooster in via the press jaw fixture. Slide the retaining bolt of the press machine in as far as it will go.
- 9b To open the PressBooster jaw, pull the handle at the hinged adapter jaw back. Place PressBooster onto the MegaPress XL ring by inserting the ball heads of the hinged adapter jaw into the contact points of the XL ring. Push the handle forward to close the hinged adapter jaw.
- 9c Hold the trigger until the actuator has engaged the MegaPress XL ring. The PressBooster requires two presses of the trigger to execute a complete press. A third press may be needed to initiate a release cycle to reset the rollers back to the original position.

Pressing with MegaPress Z3 Actuator

- 10a** On the press tool, rotate the retaining pin handle 180 degrees and pull it out to open the slot for the actuator. Insert the Viega Z3 actuator into the slot on the press tool. On the press tool, push the retaining pin back in and rotate it 180 degrees.
- 10b** Open the Viega Z3 actuator by pulling the handle back. Place the open Viega Z3 actuator onto the MegaPress XL ring by inserting the ball heads of the actuator into the contact points of the XL ring. Close the Z3 actuator.
- 10c** Start the pressing process by holding the press tool trigger until the actuator has engaged the XL ring. When the press cycle is complete, the actuator will stop and release.



The installation, inspection, testing and purging of the fuel gas system shall be in accordance with local codes or, in the absence of local codes, in accordance with the International Fuel Gas Code, NFPA 54/National Fuel Gas Code z223.1, the Uniform Plumbing Code, NFPA 58 or CSA B 149.1 as applicable.

- 11** A Vertical clearance
B Horizontal clearance
C Minimum clearance between 2 ball valves
D Minimum clearance between 2 ball valves, handles facing each other

Ball Valve	a for A, B, C	a for A, B, C	a for D	a for D
2½"	11.2"	285 mm	22.4"	570 mm
3"	11.2"	285 mm	22.4"	570 mm
4"	13"	330 mm	26"	660 mm



Warning!

This ball valve has two screw-in pieces. Once the valve is pressed, DO NOT attempt to adjust the screw-in pieces.



Warning!

Pipe wrench flats are only allowed on the nut of the valve, not on the adapter piece, housing, or any other piece. Do not use pliers to turn the ball valve, only a pipe wrench.



Caution!

Ball valves are to be use in only the fully closed or fully opened position.



Valves must be exercised from fully opened to fully closed periodically to assure continued function. Viega recommends valves be put on a routine, periodic maintenance program.