

Tech Data

Viega Seals and Gaskets Information



This document is subject to updates. For the most current Viega technical literature please visit www.viega.us.



Viega products are designed to be installed by licensed and trained plumbing and mechanical professionals who are familiar with Viega products and their installation. **Installation by non-professionals may void Viega LLC's warranty.**



WARNING!

Product line application guides and chemical compatibility matrix are not all inclusive.



All sealing elements are installed using an H-1 food grade silicone oil lubricant registered with NSF, USDA and approved for use under FDA 21 CFR.

Refer to product line application guides or chemical compatibility matrix for general information, or call Viega® Tech Services at 1-800-976-9819.

FKM Sealing Element

Operating temperature:
14°F to 284°F (-10°C to 140°)

Resistant to thermal spikes to 356°F (thermal spikes are temperature increases above maximum defined operating temperature for a duration of 24 hours or less).

FKM, is a fluoroelastomer or synthetic fluorinated rubber, specialty purpose elastomer.

FKM sealing elements are dull black in color, and possess excellent resistance to chemicals, higher temperatures, aging, ozone, sunlight, weathering, environmental influences, oils, and petroleum-based additives.

FKM's resistance to aggressive chemicals and higher operating temperatures makes it ideal for seals and gaskets in solar and industrial process applications.

HNBR Sealing Element

Operating temperature:
-40°F to 180°F (-40°C to 82°C)

HNBR, or Hydrogenated Nitrile Butadiene Rubber, is a speciality purpose compound used where resistance to petroleum-based additives are required.

HNBR sealing elements are yellow in color, and possess excellent physical strength and retention properties after long-term exposure to heat, oil, and chemicals.

HNBR sealing elements are used for applications of natural, propane, mixed, and manufactured gases as well as oils and lubricants.

HNBR's unique properties have resulted in wide adoption in automotive, industrial, and assorted high performance applications.

EPDM Sealing Element

Operating temperature:
0°F to 250°F (-18°C to 120°C)

EPDM, or ethylene-propylene-diene rubber, is a synthetically manufactured and peroxidically cured all-purpose elastomer.

EPDM sealing elements are shiny black in color and possess excellent resistance to aging, ozone, sunlight, weathering, environmental influences, alkalis and most alkaline solutions along with chemicals used in a broad range of applications, including ketones. EPDM has particularly good resistance to hot water, making it ideal for seals and gaskets.

Viega Press Systems are manufactured with high quality sealing elements, installed at the factory.

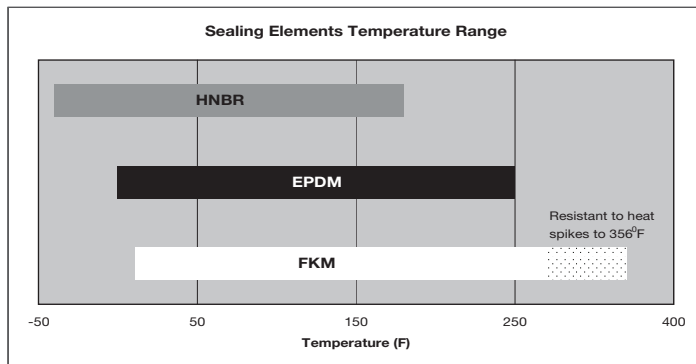

ProPress Exclusive Grip and Separator Ring

The grip ring is made of 420 (1.4021) stainless steel. The grip ring ensures the ProPress 2½" to 4" fittings create a positive cold press mechanical joint. The PBT (Polybutylene Terephthalate) separator ring ensures that sealing element and grip ring perform at maximum capacity by providing a positive physical separation.

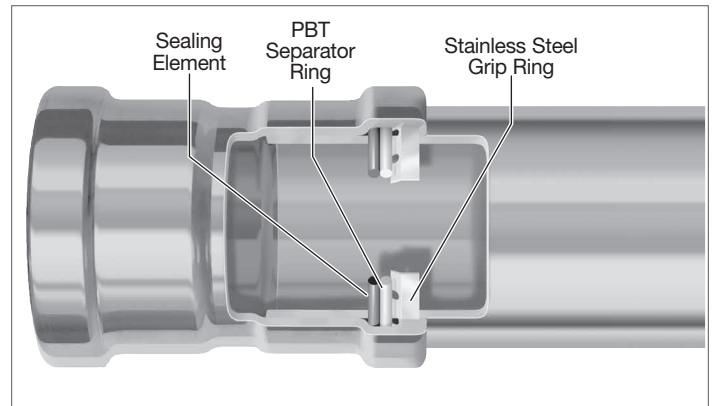

MegaPress Exclusive Grip and Separator Ring

The MegaPress grip ring is made of 420 (1.4021) stainless steel. The grip ring ensures the MegaPress fittings create a positive cold press mechanical joint. For MegaPress ½" to 2" fittings, a 304 stainless steel separator ring ensures that sealing element and grip ring perform at maximum capacity by providing a positive physical separation. For MegaPress 2½" to 4" fittings, a PBT (Polybutylene Terephthalate) separator ring protects the sealing element. For MegaPressG 2½" to 4" fittings, a graphite separator ring protects the sealing element.

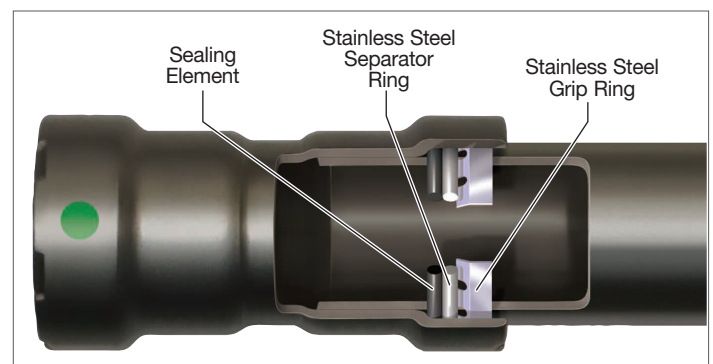

V **Viega LLC**
585 Interlocken Blvd.
Broomfield, CO 80021

Phone (800) 976-9819
www.viega.us

TD-PP 0522 Seals and Gaskets

viega